

CALL FOR A DRESSING TENDER AT THE FOLLOWING TRADE FAIR:

GULFOOD 2024

The Economic and Commercial Office of the Embassy of Spain in Dubai in the name of ICEX SPAIN TRADE AND INVESTMENT, E.P.E., (from now ICEX), hereby convenes a tender for the construction, assembly, maintenance and dismantling works of the Pavilion of Spain at the following International Trade Fair:

Trade Fair	Date	Venue	Estimated surface
GULFOOD 2024	19-23 February 2024	Dubai World Trade Centre, Dubai, UAE	1.500 sqm

Tender bidding specifications (VAT excluded).

ICEX is a Spanish institution based in Spain for all purposes.

The tenders should include a breaking down in which the price offered, and VAT must be clearly described and separated.

ICEX will evaluate the tenders based on the offered prices, excluding taxes.

All tenders must be submitted in EUROS excluding VAT or other taxes (taxes must be clearly described and separated).

Estimated surface: 1.500 sqm.

The price offered shall be of maximum EUROS 390/sqm, VAT excluded.

The price tendered by the bidding company for net surface may not exceed EUROS 585.000,00 (five hundred eighty-five thousand euros) EUROS 390/sqm x 1.500 sqm -, VAT excluded. Any quotation exceeding this amount will be dismissed.

All tenders and dressing projects must be sent in electronic format ONLY to [tenders@icex.es](mailto:tenders@icex.es) no later than **September 7<sup>th</sup>, 2023, 14:00** hours Dubai local time, (**12:00 hours Madrid time**).

Madrid, on the date shown by signature

The Board of Directors of ICEX (Contracting Authority),  
P.D. (Resolution of 30 September 2021. Official State Gazette - BOE no. 243 of 11.10.2021)

María Peña Mateos  
Chief Executive Officer

1

EUROPEAN REGIONAL DEVELOPMENT FUND

A WAY TO MAKE EUROPE

This service/activity is eligible for co-financing from the European Regional Development Fund (ERDF).



**BIDDING SPECIFICATIONS GOVERNING THIS TENDER**

**SECTION A- GENERAL TERMS AND CONDITIONS**

**FIRST. - Object**

The object of this Tender is the selection of a Dressing Contractor who shall be awarded the execution of the construction, assembly, maintenance and dismantling works concerning the Pavilion of Spain at the following 2024 trade fair and the purpose of the same is to achieve the best ratio between price and quality, wherefore ICEX is entitled to award the Tender to that Dressing Company which, at its sole judgement and pursuant to the offer submitted, provides the best terms:

Trade Fair	Date	Venue	Estimated surface
GULFOOD 2024	19-23 February 2024	Dubai World Trade Centre, Dubai, UAE	1.500 sqm

If the trade fair organization decides to move the date of the show to a new date in 2024, postpone its celebration to 2025, or even cancel 2024 edition so that the show would be held in 2025, it will be understood that the established agreement between the successful Awardee of the tender and ICEX will be valid for the decoration of the Pavilion of Spain at GULFOOD Show on those new dates.

Consequently, after signing the agreement, the contractor will not start any production work until ICEX gives the appropriate instructions once the definitive fair dates have been set. These instructions will be given sufficiently in advance so that all the works can be accomplished.

**SECOND. - Award Procedure**

The selection of the awardee company of this Tender shall be conducted, pursuant to the internal regulations of ICEX, and following the application of the criteria which are listed here below, based on the weighted values assigned to each of them.

CRITERIA	MAXIMUM POINTS
<b>C.1. Economic Offer /Budget</b> <u>Economic Offer /Budget must be in Document 3.</u> Most economical offer: maximum score. Rest of the offers: formula to be applied: "points per offer = (most economical offer price / each offer price) X maximum score per criteria"	30
<b>C2.-MATERIALS AND CONSTRUCTION SYSTEMS</b> (CRITERION TO BE EVALUATED BY MEANS OF A VALUE JUDGMENT. DOCUMENT 2) Degree of adequacy of the proposal to the aspects described in the Technical Specifications, based on the description of each section requested. See the Technical Specifications for details of aspects to be evaluated.	46



<p>The proposals that do not reach at least the score of 23 points in this criterion will be automatically excluded.</p>	
<p>It will be valued:</p> <p><b>STRUCTURES AT HEIGHT, FLOORS AND WALLS: up to 23 points</b></p> <ul style="list-style-type: none"> <li>- <u>Type of materials and composition</u> intended for the pieces for identification at height, floors and walls. Both the base structures of the pieces and the final finishes will be valued, so that the pieces have a continuous final surface without visible projections. It will be valued as well the lightness of the structures. <b>10 points maximum.</b></li> <li>- <u>Mechanization and assembly</u> of the identification structures in height and components of the booths: structures supported on the booths and suspended from the hall's ceiling, floors and walls. It will be valued that the different parts of the construction ensemble arrive at the fairgrounds ready to be assembled in a mechanized and fast way. The economy of time invested in the installation of the parts will be taken into account and, in particular, the assembly of floors, walls and national identification pieces at height will be valued. <b>9 points maximum.</b></li> <li>- <u>Type of material and composition destined to the identification of Spain/Spain/Spainien/ Espagne</u> corporeal letters, slogans and identification of CCAA. It will be valued so that its visibility is maximum and a high degree of luminosity is achieved. <b>4 points maximum</b></li> </ul>	23
<p><b>SEPARATIONS BETWEEN BOOTHS: up to 7 points</b></p> <ul style="list-style-type: none"> <li>- <u>Type of material and composition.</u> The degree of transparency will be evaluated. <b>2 points maximum</b></li> <li>- <u>Installation system.</u> It will be valued that it allows a quick and easy handling. <b>2 maximum points</b></li> <li>- <u>Level of stability</u> of the piece once assembled. It will be valued that the base is solid and the transparent pieces are well locked and anchored. <b>2 maximum points</b></li> <li>- <u>The integration of the lighting in the piece.</u> It will be valued that it is well visible and gives the whole the luminous effect on both sides of the base. <b>1 maximum point</b></li> </ul>	7
<p><b>GRAPHICS ON WALLS: up to 5 points</b></p> <ul style="list-style-type: none"> <li>- <u>Type of material and composition.</u> Its adaptability to a flat surface (flexibility), the weight of the material and resistance to environmental conditions, especially heat and cold, will be evaluated. <b>3 points maximum</b></li> </ul>	5

3



<ul style="list-style-type: none"> <li>- Placement system that allows quick and easy handling. It will be valued that the system gets a good tensioning of the graphic to avoid wrinkles and misalignments. <b>1 point maximum</b></li> <li>- Printing system that guarantees quality colors and image sharpness. The type of printing inks and their adherence to the base support will be valued. <b>1 point maximum</b></li> </ul>	
<p><b><u>FURNITURE/ Shelves and display cases: up to 11 points</u></b></p> <ul style="list-style-type: none"> <li>- <u>Shelves:</u> Placement system that resolves loads greater than 25 kgs without altering the design required in the project, maintaining the anchoring system and light wiring of the concealed shelf. Hidden anchorages that cover the entire thickness of the wall up to almost the entire depth of the shelf, as well as the number of anchor points/shelf and its section, will be valued. <b>4 points maximum.</b></li> <li>- <u>Showcases:</u> Glass case opening-closing system. It will be assessed that the case allows a comfortable and easy access to its interior for product placement. <b>Maximum 3 points.</b></li> <li>- <u>Intermediate shelf placement system.</u> The visual cleanliness of the supports that hold the shelf will be evaluated. <b>2 points maximum.</b></li> <li>- <u>Furniture</u> (booth chairs and seating in general) for exhibitor booths and institutional spaces. It will be assessed that are innovative, with design and qualities that stand out. <b>2 points maximum.</b></li> </ul>	11
<p><b>C3.-LIGHTING</b> (CRITERION TO BE EVALUATED BY MEANS OF A VALUE JUDGMENT ON DOCUMENT 2) See the Technical Specifications Specifications for details of aspects to be evaluated. <b>Proposals that do not reach at least the score of 11 points in this criterion will be automatically excluded.</b></p>	22
<p>It will be valued:</p> <ul style="list-style-type: none"> <li>- <u>For the walls of the booths:</u> The high efficiency LED projectors requested will be evaluated for their degree of orientability, as well as their level of illumination and degree of temperature. <b>6 points maximum.</b></li> <li>- <u>For the work areas of the stands:</u> The asymmetrical high efficiency LED projectors or similar requested will be evaluated on their degree of orientability, as well as their level of illumination and temperature level. <b>6 points maximum.</b></li> </ul>	22



<ul style="list-style-type: none"> <li>- <u>Lighting of product display shelves</u>: The lighting level and color temperature of the high efficiency and diffusion LED luminaires requested will be evaluated. <b>2 points maximum</b>.</li> <li>- <u>Show cases lighting</u>: The LED lighting system adopted in the base, side and fronts of the glass cases, the efficiency of the lighting and the degree of temperature will be evaluated. <b>2 points maximum</b>.</li> <li>- <u>Lighting of the identification in height</u>: <b>6 points maximum</b>.             <ul style="list-style-type: none"> <li>- Corporeal lettering (3D). All corporeal letters shall have homogeneous illumination of the same cool white color temperature (between 5,000-6,000K) and excellent grade color rendering (Ra 90-100). <b>3 points maximum</b>.</li> <li>- T-tubes for bottom of boxes in height. The proposed number of units per ml will be evaluated, never with a density lower than <b>18 tubes per 10 meters of box length</b>, as well as the proposed placement and combination of tubes along a complete piece of identification box. <b>3 maximum points</b>.</li> </ul> </li> </ul>	
<b>C4.-ENVIRONMENTAL CRITERIA (CRITERION TO BE EVALUATED BY MEANS OF A VALUE JUDGMENT ON DOCUMENT 2)</b>	<b>2</b>
The proposal includes materials whose composition is recyclable and environmentally friendly, as well as proposals associated with the elimination of single-use materials. Certification of timber and/or forestry products derived from sustainably managed forests - Use of eco-labeled products or other equivalent quality marks - Use of materials from recycling processes) <b>(Max. 2 points)</b>	<b>2</b>
<b>Total</b>	<b>100</b>

Responses C2-C4 will be scored as follows:

0% of allocated points	Proposal simply states that the bidder can meet some or all the requirements but does not provide information or detail on how they will do so
50% of allocated points	Compliant
75% of allocated points	Fully Compliant
100% of allocated points	Exceeds Requirements

**Tiebreaker Criteria.**

In the event of a tie in the score obtained by two or more bidders, it will be resolved by applying the social criteria indicated below, in order and referring to the end of the proposal submission period. The supporting documentation of the tiebreaker criteria referred to in this clause will be provided by the bidders at the time the tie occurs, and not beforehand.



- Greater percentage of workers with disabilities or in a situation of social exclusion in the workforce of each of the companies, prioritizing in case of equality, the greater number of permanent workers with disabilities in the workforce, or the greater number of workers included in workforce.
- Lower percentage of temporary contracts in the workforce of each of the companies.
- Greater percentage of women employed in the workforce of each of the companies.
- The tie if the application of the previous criteria had not given rise to a tiebreaker.

ICEX reserves the right to collect information on any incomplete aspects or questions that may arise from the bids submitted by the participating companies. Participating companies must correct the defects by the deadline indicated in each case.

Every Company taking part in the tender shall receive appropriate notice on whether ICEX has decided to award them the Contract or otherwise.

ICEX may consider that no bidders qualify for the award of the tender if following the bids and documents submitted these do not comply with minimum requirements like solvency of the Contractor, the technical project, its suitability or the prices quoted.

ICEX reserves the right to revoke the award at any time if the winning bidder fails to fulfill any of the requirements in the Call for Bids and the General Terms and Conditions governing the tender.

The bidder with the highest score will be informed of the award as soon as possible.

### THIRD. - Award sum

The price offered by the bidders shall include, among others, all expenses even those regarding fluctuations in exchange rates and cannot be modified during the period of the agreement and, if applicable, its extensions, unless express Contract thereon by the Parties.

The price tendered by the bidding company for net surface may not exceed EUROS 585.000,00 (five hundred eighty-five thousand euros) EUROS 390/sqm x 1.500 sqm, VAT excluded.

Any quotation exceeding this amount will be dismissed.

This is an estimated cost; if the Sqm of the Pavilion vary, it will imply a variation of the cost, according to the price per Sqm.

The price per Sqm specified in the tender, may not be varied or amended in any way by the Awardee, during the period of the Contract and following extensions unless express Contract thereon by the Parties.

The price per Sqm tendered must include all works regarding the construction, assembly, provision and connections of additional mechanisms and devices necessary to make all the equipments work, even those rented by the exhibitors such as refrigerated displays, audiovisuals, etc., maintenance and disassembly of the Spanish Pavilion, as well as all expense items arising from transport from and to the site where the Fair is held, and the necessary equipment for assembling and dismantling the Pavilion, warehousing and transport of loads within the Fair and rental of whatever other services are required within the Fair in order to execute the Agreement.



The price must also include:

- **Set up, maintenance and dismantling labors**, supervisor labors, Truckage charges, disposal costs, management fees, or the production and hanging labour (installation and dismantling) of all the hanging elements if required.
- **Disposal of Waste**. The wastes from the exhibition, used materials, and all other wastes in and around the booth shall be removed by the awardee (Construction and exhibitors wastes). The expenses for the disposal work shall be borne by the awardee. This cost will be included in the tender price.
- **Wi-Fi service** for the entire Pavilion.
- **Cleaning** of the Pavilion during assembly, celebration and dismantling periods.
- **Civil liability insurance**.

No additional extra costs will be accepted.

The price does not include:

- **Electricity and Power supply**  
The Organizer will provide the main electrical line construction of the primary side up to 100 V (single-phase) / 300 W per one booth. The main supply circuit will be connected to the area of the booth and a switch will be installed. Additional connections and secondary wiring works, as well as electricity costs, shall be borne by the Awardee.
- **Water Supply and Drainage Facilities**  
The main water supply and additional piping works as well as the water charges shall be borne by the Awardee. Dos millones cuatrocientos cincuenta y siete mil

The amount of Electrical works and water Supply and Drainage should be calculated separately, and the tenderer must submit an estimate, clearly and distinctly specified in the tender bid.

FOURTH. – Estimated Contract Value

The **estimated value of the contract** considers the value of the first contract, the value of three (3) possible extensions, and the possible modifications.

According to the latter, the **estimated total contract value** of these contracts is **two million four hundred fifty-seven thousand euros (2.457.000,00 €)**, VAT excluded, which includes the following amounts:

- |                                    |                  |
|------------------------------------|------------------|
| - Main contract maximum budget:    | 585.000,00 euros |
| - First extension maximum budget:  | 585.000,00 euros |
| - Second extension maximum budget: | 585.000,00 euros |
| - Third extension maximum budget:  | 585.000,00 euros |
| - Modifications (máx. 20%):        | 117.000,00 euros |

FIFTH. - Price and payment arrangement

The total price will be paid, following submission of the appropriate invoice, in the terms that ICEX and the Awardee Company agree.



ICEX will satisfy the amount specified in the tender in instalments. The first instalment of 50% will be paid upon contract signing and Contractor's presentation of the corresponding invoice.

The second instalment corresponding to the remaining 50% of the total price agreed will be paid within thirty (30) days after the conclusion of the fair upon presentation of the corresponding invoice, issued in EUROS, once the penalties, if any, have been deducted.

Administrative requirements for billing (Invoicing details):

- All invoices must be billed to:  
ICEX España Exportación e Inversiones, E.P.E.  
Paseo de la Castellana 278  
28046 Madrid (Spain)  
VAT number: ESQ - 2891001F (ICEX is VAT registered in Spain)
- And dispatched to:  
ICEX España Exportación e Inversiones, E.P.E.  
Economic and Commercial Office in Dubai  
Emirates Towers 26 floor, 504929 Dubai, United Arab Emirates  
VAT number: ESQ - 2891001F (ICEX is VAT registered in Spain)

#### SIXTH. - Procedure

This briefing will be circulated to multiple Companies, and will be published on the on the Economic and Commercial Office of Spain in Dubai portal link <https://www.icex.es/es/quienes-somos/donde-estamos/red-exterior-de-comercio/AE/convocatorias>

The Companies interested in bidding may contact ICEX ([tenders@icex.es](mailto:tenders@icex.es)) with any questions about the tender before September 5<sup>th</sup>, 2023, at 10:00 hrs. Dubai Time, (08:00 AM Madrid time).

Please note that any expenditure incurred by candidate Companies in the preparation of the proposals presentation and quotes will be at the expense of those companies involved. Submission of the offer will not generate any fees or reimbursement of any type of expenses.

Submission of an offer and participation in this tender implies the Company express acceptance of all the points contained in this briefing.

The proposal needs to be sent via email to [tenders@icex.es](mailto:tenders@icex.es) before September 7<sup>th</sup>, 2023, at 14:00 hrs. Dubai Time (12:00 hrs. Madrid time).

All files should not exceed 4mb in size if sent as attachment; should files be larger, use a file transfer service, which you have verified works.

The proposal will need to be presented in English, electronically as a pdf and where appropriate, use Excel for numbers.

All competing Companies submitting a proposal should be aware that ICEX Legal Services will review the documentation submitted to ensure that they comply with the requirements of this tender.





After verifying compliance with the Company requirements (see Document 1), the technical offer (work proposal see Document 2) will be reviewed and evaluated. Once the evaluation scores have been assigned to the technical proposal, the economic offer and automatic criteria (Document 3) will be opened and evaluated. **The price contained in the economic offer will not be known until that moment.**

A decision will be made within an estimated period of four (4) weeks from the published proposal due date. The decision will be officially notified via email, to enable the selected agency to begin work promptly.

**Proposals not submitted within the deadline will be excluded.**

Non-compliance with any of the requirements established in the present tender will result in the disqualification of the Company concerned.

Proposal submission must be divided into three (3) separate documents detailed as follows:

All the documentation shall be submitted only in ELECTRONIC FORMAT.

**- Document 1: LEGAL DOCUMENTATION TO BE SUBMITTED**

The Tenders shall provide detailed information about their companies with reference to the following items:

- Legal status, structure, size (turnover, number of employees).
- All competing bidders will be required to provide a solvency report in order to prove that the annual volume of business, referred to the best exercise within the last three available depending on the dates of constitution or start of activities of the bidder and submission of offers, is equal to or greater than **585.000,00 euros**, VAT excluded.
- Mention of other dressing projects in which they have been involved in the last three years, with special skills on dressing projects for National Pavilion at Trade Fairs.
- As well as a Letter of acceptance signed by a legal representative of the company whereby, they accept each and every term and condition set out in this Call for a Dressing Tender and its Bidding Specifications.

**- Document 2: TECHNICAL DOCUMENTATION TO BE SUBMITTED**

The offer must necessarily include:

- Plans of the proposal, including ground plans elevations with dimensions, and overall perspectives to show a proper comprehension of the project.
- Project specifications, including finishes, materials and construction processes. These specifications must take into consideration the aspects indicated in the "Specifications of Works".
- Specifications and details of the booths & overhead's structure lighting. Specifications and technical details, including luxes and temperature of light data, design, and type of the luminaires, color and adjustability of the spotlights.
- Specifications of the Environmental proposed project.
- Perspectives and/or 3D computer graphics to show a proper comprehension of the project.
- Layout with the proposed position of the luminaires in walls.

9

EUROPEAN REGIONAL DEVELOPMENT FUND

A WAY TO MAKE EUROPE

This service/activity is eligible for co-financing from the European Regional Development Fund (ERDF).

CSV : GEN-b751-2df2-6497-bb8b-2fc2-0a5e-9045-18ec

DIRECCIÓN DE VALIDACIÓN : <https://sede.administracion.gob.es/pagSedeFront/servicios/consultaCSV.htm>

FIRMANTE(1) : MARIA PEÑA MATEOS | FECHA : 12/07/2023 13:30 | Sin acción específica | Sello de Tiempo: 12/07/2023 13:31



The information provide in Document 2 does not clash with the information required in Document 3. The tenderer must avoid introducing in Document 2 any reference with the prices.

- Document 3: ECONOMICAL PROPOSAL

Economic proposal must be in EUROS.

- Breakdown of the total cost in estimated percentage:
  - Previous works-Production (booths, electricals, water, etc): %
  - Site works (set up and dismantling): %
  - Transportation, load and unload service: %
  - Management and operation services fees: %
- Detailed budget by chapter and by item, stating the unit prices.
- Electricity and Power supply. Calculated separately; not included in the tender price).
- Water Supply and Drainage Facilities. Calculated separately; not included in the tender price).

ICEX will evaluate tenders based on the offered prices, VAT excluding.

The tenders should include a breakdown in which the price offered, and taxes are clearly separated.

Proposals exceeding the maximum available budget 585.000,00 EUROS (EUROS 390/sqm x 1.500 sqm), taxes excluded, will not be considered.

SEVENTH. -Entering into an Agreement

The legal relationship between the successful Awardee of the tender and ICEX shall be recorded following the execution of a Contract. Prior the signing of this Contract, the Awardee must submit within the terms established for the same, the documentation foreseen in the Schedule of these Bidding Specifications (Annex 1 and Annex 2 only for the awardee).

EIGHTH. – Procurement Board

Appointed members of the Procurement Board for purposes of this tender will be:

President	Elisa Carbonell	General Director of Internationalization
Substitute	María Naranjo	Food Industry Director
Member	Salomé Martínez	Food Industry Assistant Director
Substitute	Alberto Blanco	Architecture department Manager
Member	Andrés Salinero	Economic and Commercial Counsellor. Trade Commission of Spain in Dubai
Substitute	Álvaro Angulo	Commercial Attaché - Trade Commission of Spain in Dubai
Member	Raúl Viña	Market Analyst - Trade Commission of Spain in Dubai
Substitute	Mercedes Fernández	Market Analyst - Trade Commission of Spain in Dubai
Secretary	Pedro Patiño	Head of Procurement Department
Substitute	Pablo Jorge	Member of the Procurement Department.



#### NINETH. - Extension of the contract

In order to uphold the institutional image of Spain at International Trade Shows or Fairs, ICEX hereby reserves the right to extend the contract signed with the Awardee for a maximum of the following three (3) editions of the Trade Fair regardless the date of execution without convening a new tender.

The general terms and conditions of the Bidding Specifications governing this Tender shall apply to the extension.

#### TENTH. – Modification of the contract

Once the contract has been formalized, the modifications considered necessary for its correct execution may be agreed, as long as they do not alter the global nature of the initial contract or imply a substantial modification. For these purposes, those whose cost implies a variation in the contract price of more than 20% will be considered a substantial modification.

Possible changes in the contract price may be due to a change in the fair location or to new functionalities in the program of needs and / or equipment of the institutional stand or company stands, the inclusion of elements that reinforce the signage at height, which it may be necessary to introduce in this or the next three (3) editions of this fair if the contract is extended.

In this case, the successful tenderer will provide in writing, at the request of ICEX, the technical, economic and other conditions, before carrying out any modification to the contract. The modification must be previously approved by ICEX and formalized in the corresponding contract.

#### ELEVENTH. - Force Majeure or restrictions imposed by the Fair Ground Authorities

The successful Awardee of the tender and ICEX will not be responsible for the damages and losses caused to the other party for delays or breaches of the contract that bring their cause in cases of *force majeure* or restrictions imposed by the Fair Ground Authorities. The duties of this contract will be considered suspended while the situation of *force majeure* or trade fair restriction lasts, and the parties will try to reach an agreement in good faith that benefits their respective interests as much as possible. In any case, the party that has knowledge of these facts must inform the other as soon as possible so that said duties are suspended or that the measures deemed appropriate are adopted. If the cause of *Force Majeure* or trade fair restriction extends in time until 2024, either party will be entitled to request the termination of the contract without having to indemnify the other party for it.

#### TWELFTH. - Cancellation or postponement of the fair

In the event that the Tradeshow is not held in 2024 or 2025, or the Pavilion is cancelled in 2024 and 2025, ICEX shall solely satisfy the expenses incurred by the Contractor as from the date of award of this contract (and in connection with the same) until the date of formal notice of this circumstance by ICEX. In order to be reimbursed, the Contractor shall previously submit all documentary invoices of the expenses incurred up to that date. In the same way, the Contractor shall reimburse ICEX the amount advanced of the expenses not incurred.

#### THIRTEENTH. -Execution of the contract



ICEX Project Manager is ultimately responsible for setting up the Pavilion. In the absence thereof, the Coordinator or Manager of the Spanish Pavilion will have ultimate responsibility. Any specific requests made by the exhibiting companies shall be responded to after consulting Project Management. The successful bidder shall not, under any circumstances, respond directly to oral requests, which must be addressed to: [dubai@comercio.mineco.es](mailto:dubai@comercio.mineco.es)

All construction, assembly and dressing work, in connection with the Pavilion, must be completed twelve (12) hours before the Trade Fair Opening at latest except in the event of force majeure or restrictions imposed by the Fairground Authorities. The last day of such works shall be devoted to cleaning tasks in general and attention to stands. The Pavilion must be completely clean one (1) hour before the Trade Fair opening.

All works must be conducted pursuant to the technical specifications set out in these bidding specifications (Section B – Technical Specifications) and with adequate materials/furniture and finish, whereby faulty or low-quality materials shall not be acceptable.

The Awardee is likewise obliged to dismantle the stands within the term and provisions contemplated in the Regulations of the Enclosure, as well to the instructions given by ICEX or its representatives at the Trade Fair.

#### **FOURTEENTH. - Obligations of the Contractor**

The Contractor shall be responsible for compliance of all technical regulations established by the Trade Fair Regulations, and to submit them layouts needed for approval as well as for the payment of the deposits asked by Organisers to allow the works at Exhibition Hall that have to be included in the Tender price.

The Contractor shall avail itself of the necessary human and technical resources in order to meet its obligations. In the event that the Contractor subcontracts any of the works herein assigned to the latter, only the Contractor shall be held liable to ICEX, without recourse to the subcontracting company.

Likewise, the provisioning of services and obtaining the necessary permits and authorisations and insurance required to undertake the assembly, dressing and dismantling works concerning the Pavilion shall be fully met by the Contractor. In any event, the Awardee must take out a civil liability insurance which covers any claims filed following personal or property damages or losses suffered by workers, exhibitors, visitors or any other person during, or as a consequence, of the assembly, dressing or dismantling of the Pavilion. All costs arising from these items must be included in tenderer's price offer.

The Contractor hereby undertakes that throughout the assembly process of the Pavilion, it shall appoint a person vested with sufficient capacity to order the changes which may be required following unforeseen or uncomfortable circumstances during the assembly process.

The Contractor shall likewise provide ICEX with the number of workers required in order to help the exhibitors during the afternoon previous to the Trade Fair inauguration and the morning in which the Trade Fair has been inaugurated and at least two (2) members of its "in-house" personnel to ensure "on-site" proper maintenance of the Pavilion throughout the Tradeshow.

ICEX is entitled to amend or cancel specific items and in that event the Contractor shall be notified of the foregoing sufficiently in advance.

12

EUROPEAN REGIONAL DEVELOPMENT FUND

A WAY TO MAKE EUROPE

This service/activity is eligible for co-financing from the European Regional Development Fund (ERDF).

CSV : GEN-b751-2df2-6497-bb8b-2fc2-0a5e-9045-18ec

DIRECCIÓN DE VALIDACIÓN : <https://sede.administracion.gob.es/pagSedeFront/servicios/consultaCSV.htm>

FIRMANTE(1) : MARIA PEÑA MATEOS | FECHA : 12/07/2023 13:30 | Sin acción específica | Sello de Tiempo: 12/07/2023 13:31



#### FIFTEENTH. – Subcontracting

The contractor will not be allowed to subcontract any of the works assigned hereof, unless ICEX previous authorization. In that event, exclusively the contractor will be held liable before ICEX for the works or omissions of the subcontracted company.

#### SIXTEENTH. - Ownership of the designs

All designs used in the Spanish Pavilion are the proprietary ownership of the ICEX, and may not be reproduced, copied or used by the Contractor for any other clients or projects.

#### SEVENTEENTH. - Health and Safety at Work

The Awardee shall be responsible for compliance of all industrial, health and safety regulations established by the legislation of the country in which the Trade Fair is held and by the Regulations of the Enclosure.

#### EIGHTEENTH. – Penalties

##### 18.1 Assembly

ICEX may impose penalties following an inadequate or poor finish, the use of faulty or badly preserved materials, and in general, for any assembly deficiencies. Such penalties shall be reckoned pro rata to the damages caused.

Any delivery delay on the agreed schedule (12 hours before each one of the Trade fair Openings) shall entail a 4% penalty on the total amount of the Contract for each of the first three (3) hours or fraction of an hour, with an additional 10% surcharge from the fourth to the sixth hour. Should the delay exceed six (6) hours, ICEX shall study the appropriate penalty thereon, which in no event shall be more than the result of applying 50% to the total consideration of the Agreement.

In the event that the works are not completed when the opening of the Fair takes place, ICEX may, notwithstanding the penalties foreseen in the foregoing paragraph, claim damages from the Contractor (likewise referred to as the Awardee).

When delay in completion of works is due to any breach of the Trade Fair Regulations, the penalty system abovementioned shall be enforced.

If all the required elements of the stands are not made available to the participants in due time and manner, ICEX is entitled to apply the penalties it deems appropriate, and ICEX reserves the right to lease such elements to third parties.

##### 18.2 Dismantling

ICEX may establish penalties in the event of an inadequate dismantling and withdrawal of the elements used in connection with the decoration of the Pavilion, pursuant to the Fair Grounds Regulations thereon pro rata to the damages caused.

Breach of the dismantling schedule as set out in the Fair Grounds Regulations shall entail the application of a penalty



Any dismantling delay on the agreed schedule by the Fair Ground Regulations shall entail a 4% penalty on the total amount of the Agreement for each of the first sixth hour. Should the delay exceed six (6) hours, ICEX shall study the appropriate penalty thereon, which in no event shall be less than 10% of the aggregate consideration for the Contract.

#### NINETEENTH. – Termination

ICEX is entitled to terminate the Contract following a breach of the Contractor of any of its contractual obligations, in addition to any claim for damages and legal remedies which may be available.

#### TWENTIETH. - Applicable legislation

Dressing works shall be governed by the terms of the contract entered into between the awardee Contractor Company and by the tender specifications, which shall be incorporated to the same, and in default of the above, the Spanish legislation shall be applicable.

#### TWENTY-FIRST. – Jurisdiction

In order to solve any dispute, disagreement, issue or claim which may arise from the performance or construction of the Contract executed with the successful Awardee of this tender, the matter will be referred to the ordinary Courts. The parties, renouncing the jurisdiction that may correspond, expressly submit to the Courts of the city of Madrid.

Madrid, on the date shown by signature

The Board of Directors of ICEX (Contracting Authority),  
P.D. (Resolution of 30 September 2021. Official State Gazette - BOE no. 243 of 11.10.2021)

María Peña Mateos  
Chief Executive Officer



**BIDDING SPECIFICATIONS GOVERNING THIS TENDER**

**SECTION B – TECHNICAL SPECIFICATIONS**

**DESCRIPTION OF THE WORKS TO BE CARRIED OUT**

Description of the project.

The design of the Spain Pavilion, which is presented together with this tender as ANNEX A, aims to add value to the presence and image of Spain, as well as to serve as a platform for the pavilion's exhibitors to personalise their participation in each fair.

The main basis of the project is based on the differentiation of three levels of communication:

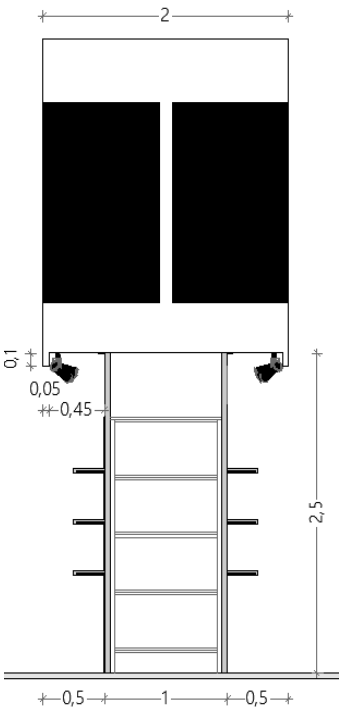
	<p>First Level (in height)</p> <p>NATIONAL signage in height (SPAIN and regional groups).</p> <p>From 2.50 m up to the maximum height permitted by the trade fair organisers.</p>
	<p>Second Level</p> <p>Signage and identification of booths (Name, booth number, company logo and E Spain logo).</p>
	<p>Third Level.</p> <p>Exhibition area with 2 m high walls. 100% customised walls with the exhibitors' graphics as part of the project.</p>

Código seguro de Verificación : GEN-b751-2df2-6497-bb8b-2fc2-0a5e-9045-18ec | Puede verificar la integridad de este documento en la siguiente dirección : <https://sede.administracion.gob.es/pagSedeFront/servicios/consult...>



## BOOTH'S STRUCTURE

### 1.-FLOORING

The floors will be made in any system that allows the passage of cables and installations to be concealed without distorting or altering the continuity of the surface.

The height of the floor shall not exceed 4 cm in height. In this case, the floor must have a wedge-shaped piece around its entire outer perimeter to allow complete accessibility for all visitors to the fair.

This wedge shall be designed in accordance with the following size scale:

X cm height (max. 4cm) x 2X cm linear development. A section of the piece is provided for graphic clarification:

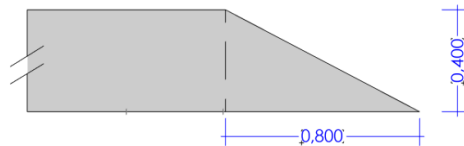

The finish shall be black, and the materials may be laminates, vinyl rolls, etc. Carpets will not be accepted.

ID for Regional Groups. A vinyl adhesive sheet, in the corporate colour of the Regional Group, will be installed on the floor of each stand, under the work table. The piece, which will have an organic amoeba-like or simply circular shape, will be highly resistant to abrasion and fire.

During the assembly process of the booths, the floors shall be protected. The necessary cleaning and removal of the protective covers before the opening of the fair shall be included in the quotation.

The contractor must comply with and include in the proposal the accessibility solutions required by the trade fair organisers.

The floor finishings must comply the following conditions:

- Durability sufficiently proven by experience.
- It shall be easy to clean by domestic procedures.
- The finish shall be non-slip.
- The edges of the level change shall be sufficiently protected.
- The positioning to the base shall ensure the stability of the finish under very high traffic.
- The platforms, where applicable, shall be rigid, flat and stable. They shall withstand a minimum of 250 kg/m<sup>2</sup>.
- The materials shall be expressly fireproof, observing at all times the specific requirements of the contract.





Aspects to be assessed in the criteria table:

**MATERIALS AND CONSTRUCTION SYSTEMS**

- Types of materials and composition.
- Mechanisation and assembly of the pieces that make up the floor in order to minimise assembly times.

**2.-REAR WALLS**

The rear walls shall be the axis that configures the contracted spaces for the pavilion. They shall be raised to a maximum height of 250 cm above ground level (including the thickness of the stand floor), and shall delimit the storage areas, the depth of which shall be 100 cm.

The side walls shall be set back 10 cm from the edge of the platform.

The resulting structure shall comply with the following objectives:

- Principle of stability.
- Capacity to accommodate maximum storage for exhibitors' goods.
- Ability to conceal the electrical panels and lighting equipment inside (space shall be provided to conceal the electrical panels at the ends of the islands). In any case, electrical switchboards may not be placed in the storage spaces allocated to the booths.
- Continuous look construction without interruptions. Concealed internal structure.

Aspects to be assessed in the criteria table:

**CHARACTERISTICS OF MATERIALS AND CONSTRUCTION SYSTEMS**

- Types of materials and composition.
- Mechanisation and assembly of the pieces that make up the rear walls in order to minimise assembly times.

The back walls will serve as a support for the personalised graphics. The parts not covered by graphics will have a matt white finish.

2.1.- PERSONALISED GRAPHICS FOR EACH BOOTH.

The main focus of the project is the custom designed graphics that each booth will have covering the entire dimension of its back wall (in height-200cm x the individual length of each booth), as part of the project design, included in the tender price.

The tender will include the production and installation of the graphic material, which will be made on the back walls of the booths on high quality adhesive vinyl or canvas. Rigid or semi-flexible supports will not be accepted for the graphics. The graphics shall cover the entire wall, in height and length, including the door panel of the warehouse, which shall not have visible opening knobs in order to avoid protrusions in the view of the graphics. The graphics shall be neatly stretched and the visible edges, including those of the storeroom door, shall be straight and neatly trimmed.



The shelves of each booth shall be placed on the wall once the graphic has been placed on it.

The company awarded the contract shall be responsible for attending to, supervising and coordinating the reception of the final artwork of the graphics that each exhibitor shall send them for subsequent production and installation, tasks that shall be carried out by the company awarded the contract and which are included in the bid.

## 2.2.- SIGNAGE AND IDENTIFICATION OF BOOTHS.

It shall occupy the upper part of the wall on a continuous strip of approximately 50 cm in height, and shall include the following identifying elements:

- Exhibitor company lettering.
- Label of the regional groups (if applicable).
- Booth number.
- Company logo on cut vinyl.

The letterings and booth numbers will be in dark grey vinyl, in capital letters, Helvética Neue type.

Aspects to be assessed in the criteria table:

MATERIALS AND CONSTRUCTION SYSTEMS/Graphic material on walls.

- Type of material and composition.
- Installation system.
- Printing system.

## 2.3.- STOREROOMS

The doors of the storerooms will have the same finish as the rest of the wall and will also serve as a base for the personalisation of booths with graphic images, so they will not have visible knobs. The interior will be equipped with shelves (five levels) on which standing bottles can be placed (38 cm free height between shelves), with wall hangers for coats, and a standard 500 watt electrical socket if necessary.

## 2.4.- INSTALLATION OF SHELVES FOR EXHIBITION

which will be anchored to the wall with hidden fixings, and each one of them will be illuminated with a system of LED lamps.

They shall be approximately 100cm long\* 25cm deep. The finish may be proposed by the bidder, provided that it complies with the technical specifications required in these specifications (laminated-wood in white, transparent methacrylates, metallic finishes, etc.).

The net height of separation between shelves shall be 38 cm uniformly for all booths.

Shelf's load: It is essential to bear in mind that the products exhibited at agri-food sector fairs are samples with considerable weights (bottles, jars and tins of preserves, etc.) which can



endanger the stability of the shelves. It is estimated that the racks will support an average load of 25kgs. For this reason, it will be required that the shelves are fixed with metal pins that go through the thickness of the wall and that have a reinforcement on the inside face of the wall.

Aspects to be assessed in the criteria table:

MATERIALS AND CONSTRUCTION SYSTEMS/FURNITURE/Shelves and showcases.

- Constructive solution for loads equal to or greater than 25 kgs. keeping the shelf fixings always concealed.

### 3.- DIVIDING WALLS BETWEEN BOOTHS

The separation between booths will be made with partitions whose height will be 160 cm and length 250cm. Its supporting base shall be made up of a sufficiently solid and resistant base to hold the translucent piece, and the bid must propose an installation system that ensures the complete stability of the piece.

The colour of the base shall be the same as the platform: **black**. The height and width of the base shall be kept to the minimum possible. Each piece shall be illuminated at the base with an LED system.

The material of the partition (excluding the base) will be 100% transparent in order to maintain a full view of the booths along the aisles, although a translucent acid-etched vinyl will be integrated in a circular shape (120cm in diameter) to give partial privacy between booths.

These walls will be free of signage and any other element that may obscure the total view of the rest of the booths in a row.

A detail is shown below:

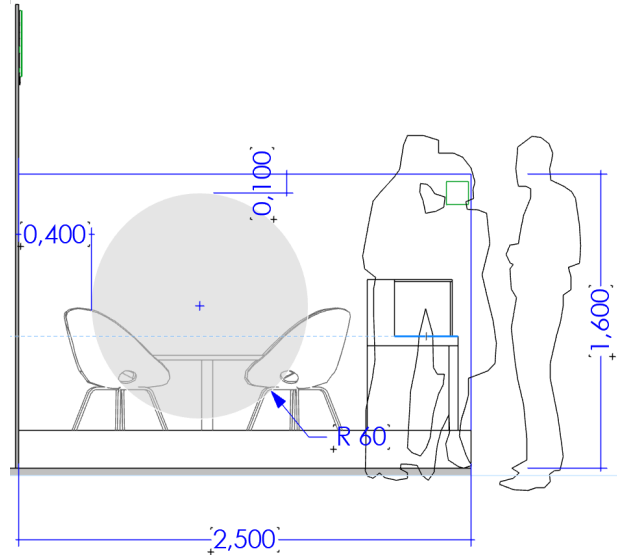

Aspects to be assessed in the criteria table:

**MATERIALS AND CONSTRUCTION SYSTEMS**  
/ Separations between booths

- Type of material and composition.
- Installation system.
- Degree of stability of the piece once assembled.
- The integration of the lighting in the piece.

**4.- BASIC EXHIBITION FURNITURE INCLUDED IN THE OFFER**

Booth dimension	Display Case with 2 supplementary wedges	Shelves (100*25cm)	Table 80	Chairs
From 6 sqm to less than 9 sqm	1	3	1	2
From 9 sqm to less than 14 sqm	1	3	1	4
From 14 sqm to less than 18 sqm	2	3	2	8
From 18 sqm to less than 24 sqm	2	6	2	8
From 24 sqm to less than 28 sqm	3	6	2	8
From 28 sqm to less than 32 sqm	3	6	3	12
From 32 sqm to less than 36 sqm	3	6	3	12
≥36,00 sqm	4	9	3	12

In addition to the above mentioned items, the basic equipment of the booths will also include:

- 1 small waste bin, with set of rubbish bags/per table for all exhibitors.
- 1 medium-sized rubbish bin, with a set of rubbish bags for exhibitors who will be tasting and cooking. Estimated supply for 20% of the booths.
- 1 cleaning kit for each exhibitor, consisting of a cleaning cloth and a spray bottle with cleaning liquid. It will be left at each stand inside the showcases.
- 1 double 500 Watt power socket for every 9 sqm of booth space, in the workspace, to connect chargers, laptops, etc. Booths between 6sqm and less than 9sqm will also have a socket.
- 1 24-hour power socket for cooling equipment up to 1,000 watts.
- 1 table-top spittoon for the cellars/for each display case.
- 1 transparent cooler (without ice) for two (2) bottles/per display case, printed with the FWS-Wines from Spain logo.

Display case



Made of high quality **black** board, with concealed fittings and screws, and transparent security glass.

Dimensions: 120 cm length \* 60 cm depth \* 100 cm height.

The display case consists of the following parts:

Glazed vase for product display, with two display levels.

Size of the vase: 60 cm L \* 60 cm H \* 30 cm deep.

The vase will be illuminated on its base and one side in backlit opal glass, as well as with LED strip lighting on the front of the display case, at 2 levels: top line of the vase and in the middle line front, running into the interior of glass shelf. It shall be made of transparent security glass.

Two supplementary wedges shall be provided for its interior to place the product on an inclined or flat angle:

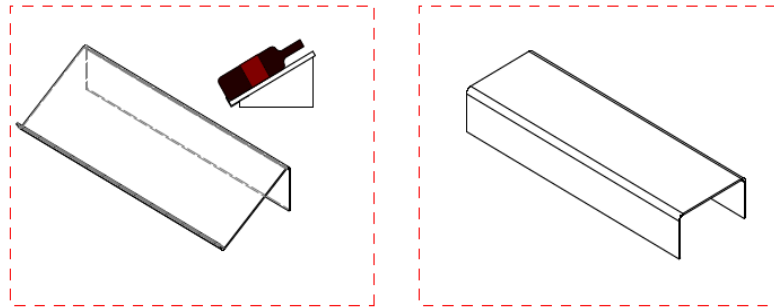

The closing-opening system of the vase that allows products to be placed inside it will be valued.

Space for installing small refrigeration equipment (110-litre fridge, wine cellar, etc.). If a fridge is not necessary, this space will be fitted out with two shelves for storing dry products. This space will be closed with a lockable door in which the heat dissipation system produced by the refrigeration equipment will be fitted by means of small holes drilled in the door panel.

Cupboard with lock. Its interior will be fitted with 2 shelves. Dimensions 95 cm H \* 60 cm length \* 30 cm depth.



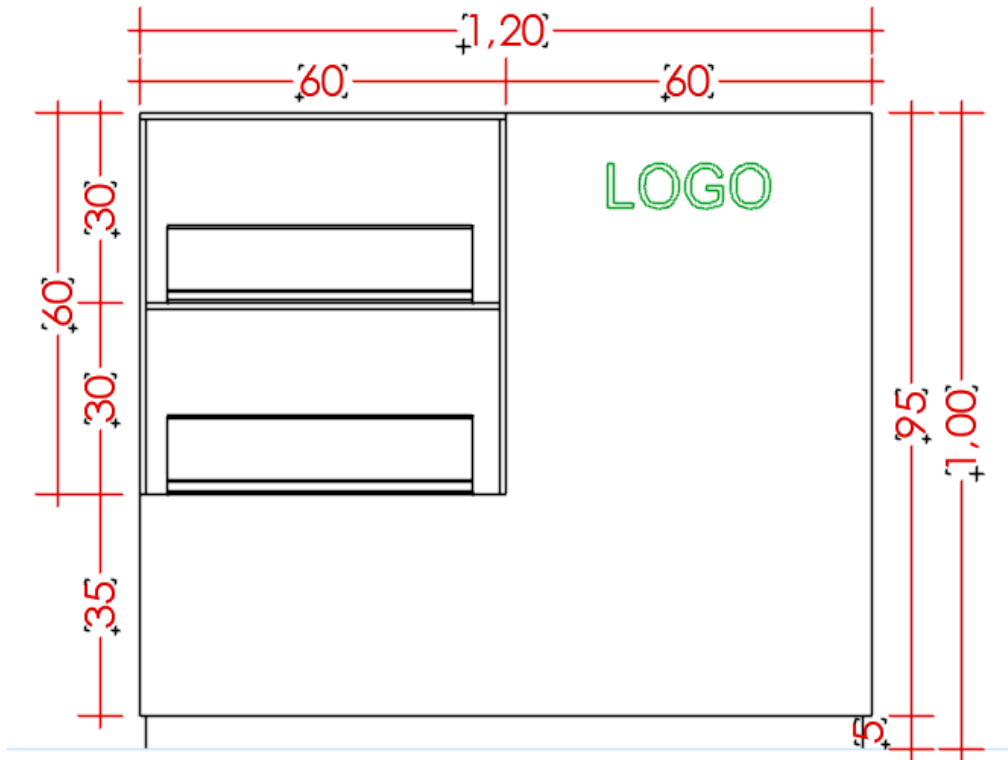

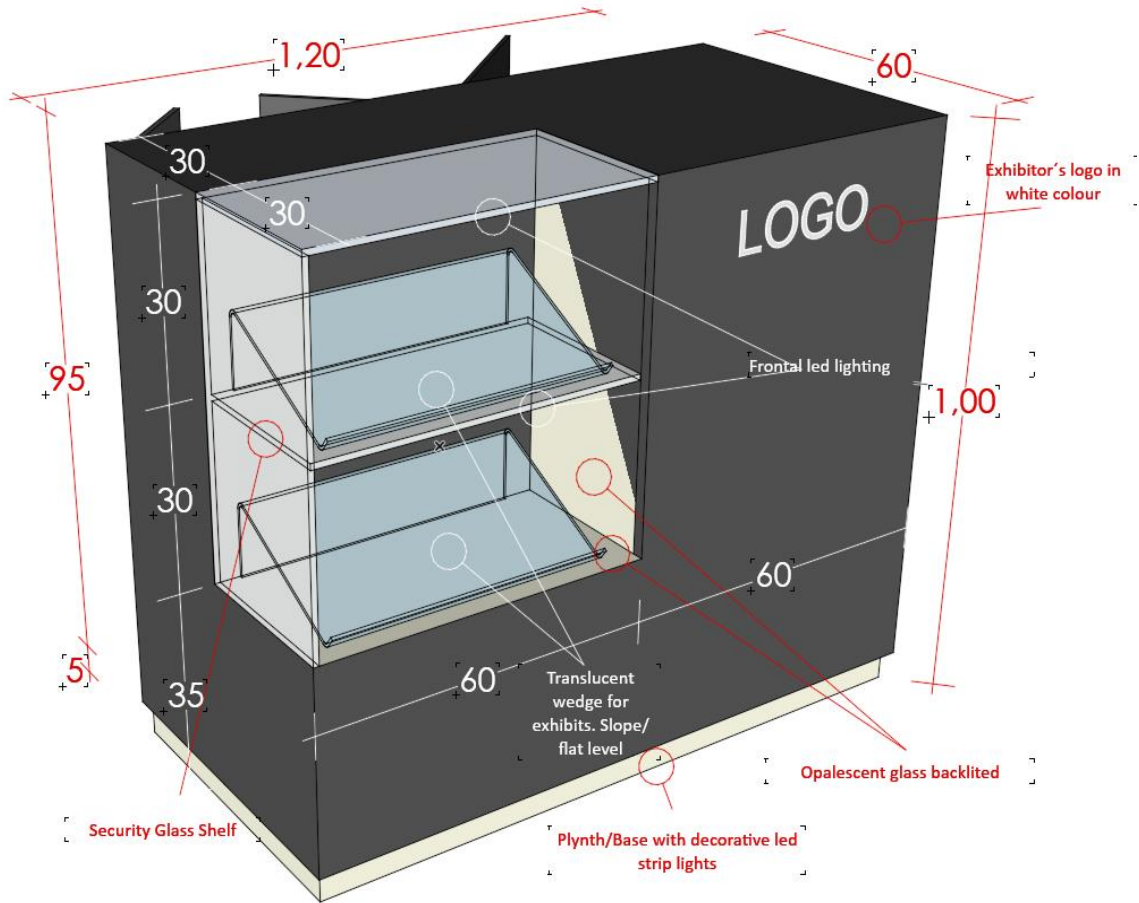

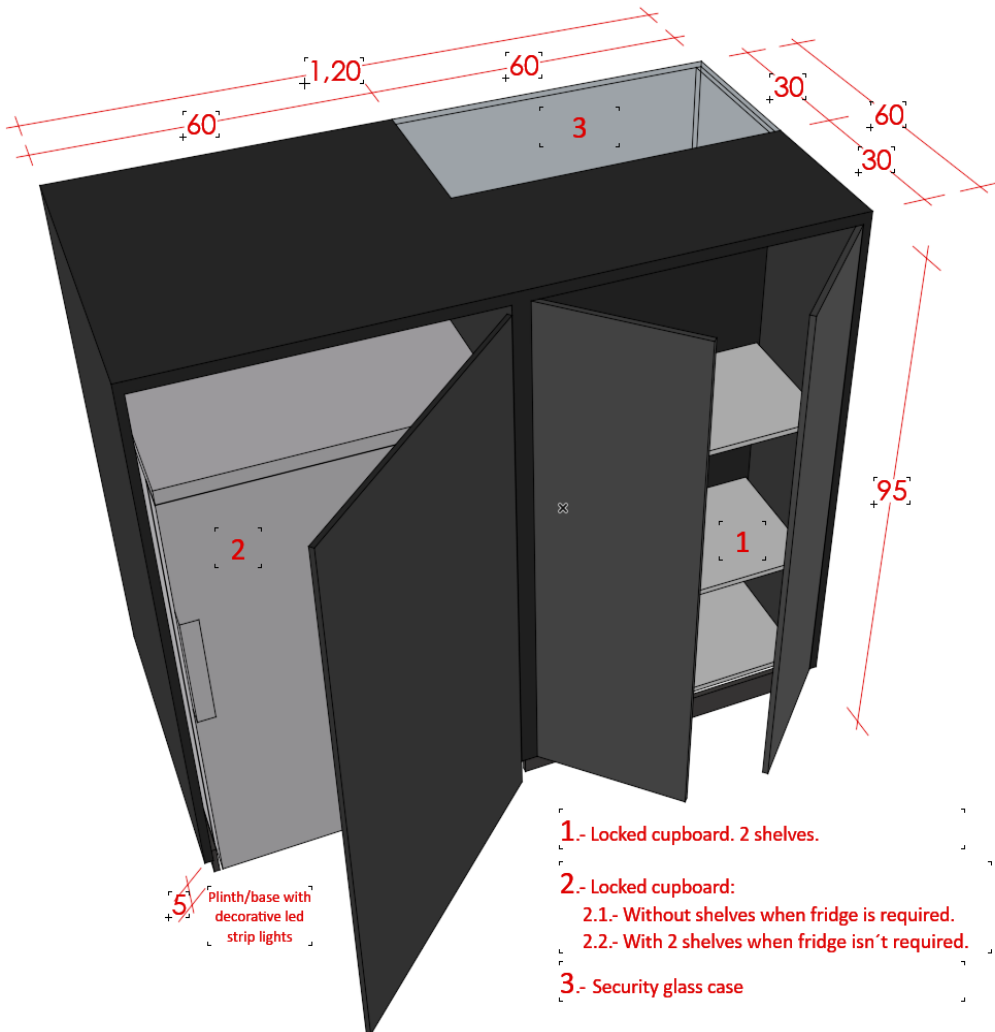

The company logo will be included on the front of all exhibition counters. This logo will always be in a monochrome version with cut vinyl.

Aspects to be assessed in the criteria table

MATERIALS AND CONSTRUCTION SYSTEMS  
/ FURNITURE/ Shelves and showcases

- Opening-closing system of the glass vase.
- Middle level shelf placement system.





### Tables and chairs

Tables shall preferably be white circular (80cm diameter), avoiding glass or transparent tops. Chairs should be white, comfortable, ergonomic and stackable. Preferably of Spanish design.

## **5.- STAND LIGHTING**

Given the importance of lighting in the project, although it has been mentioned in each of the previous points, we consider it important to recapitulate the scope requested in the bids to be submitted.

200 lux of environment lighting will be considered in order to achieve the required light intensity standards.

### 5.1.-LIGHTING OF THE WALLS AND WORK AREA OF THE BOOTHS

Lighting will be provided by a continuous cornice above the booths. Two levels of projectors with different purposes shall coexist:

1.- FOR THE WALLS OF THE BOOTHS: High efficiency LED projectors, whose diffusion will reach the entire walls, the company identification areas and the first level of the exhibition stand. Adjustable black arm spotlights shall be used, with which at least 600 lux of illumination shall be achieved.

2.- FOR THE WORK AREAS OF THE BOOTHS: Asymmetrical, high-efficiency, black, adjustable LED spotlights to illuminate the rest of the booth, including the tables and workstations, where at least 600 lux of light must be achieved. The asymmetric spotlights achieve much brighter areas and almost negligible levels of glare, thanks to their special asymmetric lens that allows the light to be redirected.

The projectors installed in the cornice must be high-powered to achieve at least 1000 lux of illumination over the full height and length of the booth walls. This minimum light output shall be considered for the lower part of the wall considering it to be white or light coloured. The light output shall not be less than 450 lux in situations where the wall or graphic is black or dark in colour. All lights must have the same cool white colour temperature (between 5,000-6,000K) and excellent colour rendering (Ra 90-100).

### 5.2.- LIGHTING PRODUCT DISPLAY SHELVES

Shelves. All shelf levels will have their own zenithal lighting, except for the upper shelves which will be illuminated by the continuous cornice above them. The lighting will use LED technology. The lamps shall be of high efficiency and diffusion, and shall perfectly illuminate the products displayed on each shelf.

At least 1000 lux of illumination must be achieved for the products displayed on the 2 lower shelves. All lights shall have the same cool white colour temperature (between 5,000-6,000K) and excellent colour rendering (Ra 90-100).

The tender shall take into account that the electrical wiring of the shelf lighting must be concealed, as well as the fixing system for the shelves. The construction solution shall be

25

EUROPEAN REGIONAL DEVELOPMENT FUND

A WAY TO MAKE EUROPE

This service/activity is eligible for co-financing from the European Regional Development Fund (ERDF).



detailed, both in the descriptive report and in drawings. Construction details shall be provided with sections and perspectives in which the lighting system is visually explained.

### 5.3.-ILLUMINATION OF SHOWCASES

They shall have a LED lighting system at all levels. Lamps with high brightness ranges and light diffusion to perfectly illuminate the products displayed on each shelf.

At least 1000 lux of illumination shall be achieved inside the display case. All lights shall have the same cool white colour temperature (between 5,000-6,000K) and excellent colour rendering (Ra 90-100).

### 5.4.-ILLUMINATION OF THE IDENTIFICATION IN HEIGHT.

All illuminated 3D-lettering shall have homogeneous illumination of the same cool white colour temperature (between 5,000-6,000K) and excellent colour rendering (Ra 90-100).

### 5.5.- LIGHTING AT THE BASE OF THE STAND SEPARATORS

The supporting base of the separating partitions between booths will consist of a sufficiently solid and resistant base to support the translucent piece and will be illuminated at the base with a decorative LED system, on both sides of the transparent panel.

Aspects to be assessed in the criteria table:

<p><b>LIGHTING</b></p> <ul style="list-style-type: none"> <li>- Lighting system for the walls of the booths.</li> <li>- Lighting system for the work areas of the booths.</li> <li>- Lighting system for sample display shelves.</li> <li>- Lighting system for showcases.</li> <li>- Lighting system for the high level identification: 3D-letters and T-tubes for the bottom of the high level box.</li> </ul>
--

## **6.- OVERHEAD'S SIGNAGE**

### 6.1.-DESCRIPTION:

The Spain pavilions will be identified at height, above the stand level, by means of large horizontal prismatic volumes that will crown all the spaces destined for the National Pavilion.

These volumes are defined as large boxes open on two sides (the main sides opening onto the exhibition aisle).

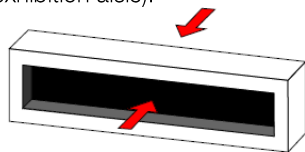

In order to ensure stability, resistance and structural support of the piece, each volume shall be built with an internal reinforcement, which shall divide the prism longitudinally in half, by means of a black panel.

The inner part of the box shall be black and the outer part may be PANTONE RED 485C or PANTONE YELLOW 124C.

Up to this point, we have roughly defined the structure of a theatre stage, which will allow us to present our story to the visitors of the fair, and for this it is time to define both the stage and the message of the country that we want to communicate.

Inside the box, we will place, on both sides, lighted corporeal letters (3D) of different typographies and sizes, as well as LED tubes that will provide movement, depth and lighting inside the box.

## 6.2. MEASUREMENTS

The prism that will define the scenographic space in height will be 2 metres deep, its length will vary according to the island or peninsula, and its height will depend on the construction restrictions of each exhibition site.

The lower part will have a 10cm recess to hide the spotlights used to illuminate the booths.

The height of the signage will be 250 cm above the level of the exhibition floor, and must always be adjusted to the maximum height permitted by the exhibition organisers.



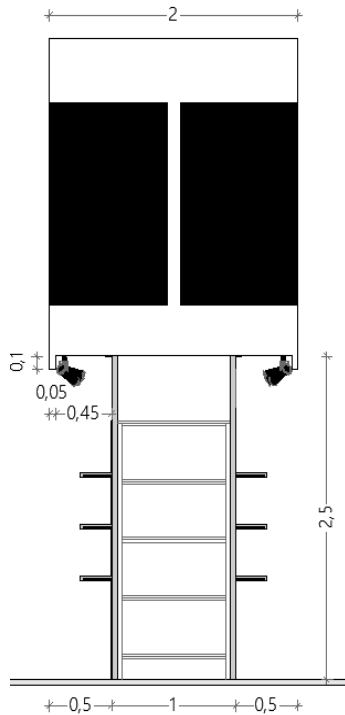

**Stand height regulations**

The maximum height for Space Only stands is as follows, including name sign or trademark. All Space Only Exhibitors must follow the height grading system:

HALL	Estimated Gross surface sqm	Max. permitted Height m
2. Dairy	95	6,00
4. Meat & Poultry	150	6,00
Za'abeel Hall 1. Fats & Oils	235	5.35
Za'abeel Hall 2. Beverages	108	6,00
Sheikh Saeed Hall 1. Worl Food	912	6,00

MAXIMUM PERMITTED HEIGHT 5.35 meters (Za'abeel Hall 1. Fats & Oils):  
 The total height shall be 2.85 m, with 54 cm perimeter frames.





MAXIMUM PERMITTED HEIGHT: **6.00 meters (rest of halls)**  
The total height shall be 3. 50 m, with 70 cm for perimeter frames.

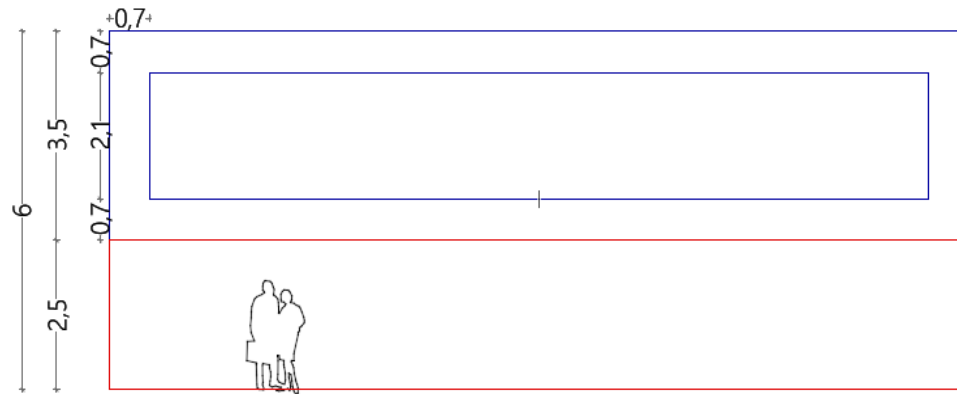

SCENARIO OF SPACES ON THE PENINSULA AND/OR WITH CONSTRUCTIVE RESTRICTIONS WITH NEIGHBOURING BOOTHS OR ENCLOSURES OF THE EXHIBITION SITE.

In those cases in which the trade fair regulations impose construction restrictions in the case of party walls with other booths and/or enclosures of the trade fair site (especially setbacks), the successful bidder must hang the signage and raise it to the maximum height permitted in each case.

In the case of booths adjoining other booths that are not part of the Spain Pavilion, and due to the setbacks required by the trade fair regulations, it is not possible to maintain the prism in its full width dimension (2m), it will be suspended with a half truss, with a single visible face and 1m deep instead of the full 2m piece.

*SUSPENDED STRUCTURES*



The complete installation (load calculations, trusses, lighting, and suspension systems, etc.) will be included in the bid price. Additional zenithal lighting will be included for the booths with asymmetrical LED projectors of high power and luminosity, from the suspended part.

6.3.-MATERIALS.

The finish shall be made of rigid materials such as wood or similar, painted or vinyl. No visible joints shall be allowed. The element must give a sense of continuity. The structure used may be aluminium profiles, wooden frames or any other structure provided that it is completely hidden.

6.4.-HEADWALLS

On all the sides of the boxes, the word

ES  
PA  
ÑA

centred on the piece, in capital letters and Bliss Light typeface. Height of the lettering 50cm  
The die-cutting shall be backlit with sufficient bright light.

6.5.- INSIDE THE BOX: CORPOREAL LETTERS (3D) AND T8 LED TUBES

CORPOREAL LETTERS

Inside the boxes there will be a series of backlit texts (Spains, slogans, Regional groups identifications, etc.) which will be corporeal, approximately 10cm thick. The letters will be placed on both sides of the box.



Texts, sizes and fonts will be as follows:

- Spain/España/إسبانيا. Typeface Bliss Light. Font size 110cm. The first letter in upper case and the rest in lower case. To be placed at one end.
- Spain/ España/إسبانيا. Typeface HelveticaNeueLT Pro-75 Bd. Font size 110cm. The first letter in upper case and the rest in lower case. To be placed at the opposite end.
- Tasting Spain. Typeface HelveticaNeueLT Pro 75 Bd. Font size 50 cm. The first letter of each word in upper case and the rest in lower case. To be placed on 2 lines.
- Spain in your Glass. Tahoma typeface. Font size 40 cm. The first letter of Spain and Glass in capital letters and the rest in lower case. To be placed on 3 lines.
- Spain in your Plate. Arial typeface. Font size 40 cm. The first letter of Spain and Plate in upper case and the rest in lower case. To be placed on 3 lines.
- Name of the participating autonomous communities. The size and typography will depend on each event and situation. Icx will send the text and instructions well in advance. It is estimated that at least the following Autonomous Communities may be present:



Extremadura, Galicia, Castilla-La Mancha, Región de Murcia, Andalucía, Comunitat Valenciana, Castilla y León and Aragón.

Texts and typographies, as well as the size of the letters may vary according to the fair and the needs.

All the words Spain/España/إسبانيا, and the names of the Regional Groups must be backlit as in the following scheme:

The lighting should be very bright and intense

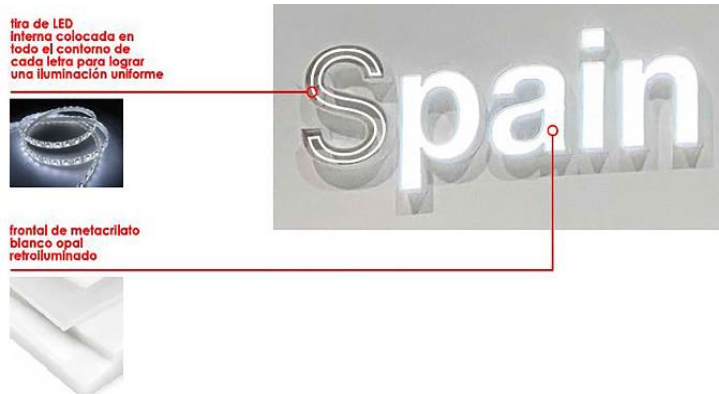

The texts must be on different levels and be legible at all times from the nearby aisles of the exhibition site.

The successful bidder must propose a system for placing the lettering in the "scenographic space", concealing the wiring and ensuring that the fastening elements are completely unnoticed and avoid concealing other lettering or lighting elements.

#### 6.6.- LED T8 TUBES. LIGHTING OF THE BOX.

This shall be done with T8 LED tubes (or larger diameter) of 150cm length and at least 24W power. The LED tubes will be placed in different planes of the box at different angles, so that they can play with the 3 dimensions of the space.

**The density shall be approximately 18 tubes per 10m length of the box.**

The tubes may not be placed in front of any corporeal lettering to avoid covering them.

The successful bidder must propose a system so that the wiring and the tube fastenings are not visible.

#### **7.- INSTITUTIONAL AREAS. Icx's booth/ Mocktail Bar/Olive Oil Tasting Corner**

Institutional spaces include all those spaces used for information booths or spaces in which ICEX organises a promotional activity within the Pavilion:



ICEX information booth. ICEX's booth will be present in each hall.  
Mocktail Bar.  
Olive Oil Tasting Corner.

### ICEX INFORMATION BOOTH

All ICEX information booths will have at least:

- 1 white ICEX information counter of simple design with interior storage for promotional material and leaflets with key and interior shelves [ approx. 2-3mx0,5m x 1m (h)]. The front shall be backlit. No aluminium modular system will be accepted. Must include a 500W double power socket inside.
- 3 high chairs, floral centre, a waste bin and hook for hanging promotional bags and waste bins.
- Full wall and floor graphics. The floors of the ICEX stand will always have images printed on the raised floor. When there are no images, the floor will be black.
- A computer, and Wifi/ Adsl line and connection for the computer equipment.
- Meeting space with 1 table, four chairs and a waste paper basket. 1 double 500 W power socket
- More relaxed meeting space with low armchairs, low table and floor lamp. 1 double 500 W power socket
- LED screen, 80" or larger with HDMI and USB input. Icex will provide the contractor with the videos to be mounted on a carousel.
- Storage furniture for promotional material and publications. Storage space with shelves, lockable cupboard, waste bin, power sockets.

A storage room to accommodate:

- Small fridge A+ in energy consumption and 24hrs power socket.
- Coffee machine with capsules (50 per day), milk (50 individual capsules/day) and teaspoons (50 per day).
- Water fountain with jerry can refill (2 refills per day).
- Shelving with 5 shelves
- 500 W power sockets required.
- Wall-mounted coat and bag racks.
- Locker cabinet or similar
- Cleaning set with paper towels and cleaning liquids.

### Mocktail bar (World Food Hall)

Estimated surface: 36 sqm

- Floors in non-carpeted finishes: fibers, melamines, vinyl floors, etc. It will be characterized by being non-slip and easy to clean.
- Graphics on all walls.
- Bar counter with 6 stools.
- 3 high tables, 12 pile up stools.
- LED screen of at least 90".





- Portable wireless microphone and speaker system.
- Storage cabinet with:
  - o Support table for glassware washing.
  - o Furniture table to prepare the cocktails, with shelves for storing bottles.
  - o Some industrial shelves with high load resistance
  - o Sink.
  - o Dishwasher.
  - o 1 high capacity refrigerator, with freezer room.
  - o Waste basket bin.

The cleaning of this area will be covered all day long, every day of the fair. There will be a cleaning team dedicated to the cleaning and maintenance of this space, in order to have the area in perfect conditions.

#### Olive oil tasting corner (Fats & Oils Hall).

Estimated space: 36 sqm

- Floors in non-carpeted finishes: fibers, melamines, vinyl floors, etc. It will be characterized by being non-slip and easy to clean.
- Graphics on all walls.
- Oil taster table.
- Reception table + one stool.
- Tasting table/s for 50 oils. Linear furniture to place tasting oil bottles.
- LED screen of at least 90".
- Portable wireless microphone and speaker system
- 10 pile up stools for assistants.
- Storage cabinet with:
  - o Support table for washing.
  - o Furniture table to prepare tastings, with shelves for storing bottles.
  - o Some industrial shelves with high load resistance
  - o Sink.
  - o Waste basket bin.

The cleaning of this area will be covered all day long, every day of the fair. There will be a cleaning team dedicated to the cleaning and maintenance of this space, in order to have the area in perfect conditions.

- Graphics on walls: Directory, Foods & Wines from Spain General Graphics, Seminar's schedule.

The cleaning of this area will be covered for the entire day of the fair, every day of the event. There will be a team of one person assigned to the cleaning and maintenance of this area, and the area must be kept in perfect cleanliness and order at all times.

#### 8.- INSTITUTIONAL SIGNAGE. ICEX CORPORATE IMAGE

The Spanish pavilions will be marked with the logos detailed in Annex B that identify them with Spain. The areas destined for reception/institutional booths will have a guide panel reflecting the distribution of the different exhibitors, guaranteeing their correct location and the logos FEDER, Foods and Wines from Spain, ICEX and the E España logo. The company awarded

33



the contract will have to comply with the information and publicity measures and the instructions for the application of the European Union emblem, which has its own specifications for agri-food promotion actions with mention of the national origin of the products. The company will prepare the posters and signage for subsequent production and implementation, under the supervision of ICEX.

## 9.- SHARED WASHING ROOMS AND KITCHEN AREAS

### WASHING AREAS.

When defined in the project, they will be equipped with:

- Support table.
- Sink with hot water supply.
- Liquid soap, brushes for cleaning wine glasses and rolls of drying paper.

These areas will be identified both on the doors and on the pavilion directories.

The cleaning of this area will be covered during the entire day of the fair, each day of the event. There will be a team of one person assigned to the cleaning and maintenance of this area, and the area must be kept in perfect cleanliness and order at all times.

## 10.- ELECTRICITY AND LIGHTING

The entire installation must comply with the regulations dictated in this respect by the fair authorities, and the successful bidder shall submit all documentation requested for this purpose.

Prior to each assembly, the company awarded the contract will check the suitability of the electrical installation with the fair's technical supervisors.

The successful bidder shall be responsible for the management of the request for electricity contracts and shall submit to ICEX, prior to the final formal request, a summary of the requests to be generated for its approval. **These expenses are not part of the bid price. IceX will pay directly to the fair organizer, the amounts that apply and have been previously approved by ICEX.**

The distribution and connections from the outlets to each of the booths, with their complete electrical installation, will be the responsibility of the successful bidder, and must be included in the price of the decoration.

Likewise, there will be specific accessible compartments for the electrical panels and cabinets. These cabinets must be fully integrated into the design and aesthetics of the pavilion and must be freely accessible to the fair organization, avoiding their placement within the storage spaces of the booths.

Lighting equipment must be sufficiently protected for use in the country of assembly, and must comply at all times with the technical regulations of the trade fair organization.

## 11.- PLUMBING

34

EUROPEAN REGIONAL DEVELOPMENT FUND

A WAY TO MAKE EUROPE

This service/activity is eligible for co-financing from the European Regional Development Fund (ERDF).



The contractor will be in charge of supplying the sinks for the water areas requested for each fair, and according to the situation indicated in the distribution plan to be validated with the successful bidder.

The successful bidder shall be responsible for managing the request for water/drainage connections and shall submit to ICEX, prior to the final formal request, a summary of the requests to be generated for approval. **These expenses are not part of the bid price. ICEX will pay directly to the fair organizer the amounts that correspond and have been previously approved by ICEX.**

**12.- CLEANING OF THE PAVILION AND COLLECTION OF DISPOSABLE MATERIALS (during assembly, celebration and dismantling periods).**

The awarded company shall deliver the Pavilion completely clean at least 12 hours before the official inauguration.

The awarded company will be responsible for the daily cleaning of the Pavilion during the days of the fair and for the supply of garbage bags and any necessary bins.

In addition to the standard cleaning service indicated above during the days of the fair, the successful bidder will establish a permanent cleaning service to attend both the booths that cook or do tastings, as well as the washing areas that need an instant and continuous waste and garbage removal service.

The cleaning of the booths will include the storage areas, exhibition furniture (interior and exterior), showcases, shelves, waste garbage cans, chairs, tables, floors and walls.

**The cleaning service of the pavilion will be included in the company's offer.**

In the event that the regulations of the fairs require the hiring of garbage containers for the removal of disposable materials, the costs of such rental, garbage removal and cleaning of aisles shall be borne by the assembler with regard to waste attributable not only to the exhibitors' material but also to that coming from the construction components of the booths of the Spanish pavilion.

The contractor shall be responsible for organizing and requesting containers for the collection of waste from all the material (constructive and exhibitors of the Spanish pavilion) and shall be responsible for any payment required by the fair organization for these services.

**13.- FEES FOR ADVANCE SET-UP OR RENTAL OF SPACE FOR OUT-OF-HOURS WORK INSIDE THE FAIRGROUNDS**

The awardee undertakes to pay any fee corresponding to the rental of space for out-of-hours work within the Fair Precinct, as well as any other fee that may be required by the Fair Organization, both at the beginning and at the end of the Show and which are not contemplated in these specifications.



In this regard, the successful bidder must respect the assembly schedule established by the Fair. Any additional assembly days that must be contracted for the perfect execution of the construction work shall be at the expense of the decorating company.

#### 14.- WIFI SERVICE FOR THE PAVILION

The Contractor will be in charge of taking the provision and installation of Wi Fi service for the entire Pavilion.

Labour to install and connect Wi Fi service must be included in the tender along with the cost of service provision. The description of that service (including Wifi routers units and range) will be necessary.

#### 15.- FIRE REGULATIONS

When required by the Fair Organization, the awarded company shall supply, within the bid price, the necessary fire extinguishers to ensure the neutralization of any possible fire incident, with a minimum of one 5 kg. extinguisher for each 100 m2 of gross exhibition area. These will bear the certificate of filling and expiration date. In the event that trade fair regulations require a greater number of extinguishers per m2, it shall be the responsibility of the successful bidder to supply them at no extra charge.

All materials used in the construction of the booths must be fireproof and have the certificates of approval required by the organization of the event.

#### 16.- SANITARY REGULATIONS

The awarded company shall have a first aid kit in the Pavilion.

The awarded company will supply hydroalcoholic gel to all exhibitors and will mount methacrylate screens on the counters if required by the Fair Organization. The successful bidder undertakes to respect and assume all the required sanitary regulations.

#### 17.- OTHERS

The use of the Pavilion shall be on a rental basis.

The facilities will remain at the disposal of ICEX and exhibitors for the duration of the Fair.

The transport and storage of the materials or decorative elements of the Pavilion shall be at the expense of the company awarded the service, which may use any means of transport.

The contractor shall be responsible for the management and contracting with the fair of all the permits necessary for the execution of the Spain Pavilion and for compliance with the fair regulations both in technical aspects and in safety and fire protection. Specifically, the company awarded the contract must ensure that the materials and solutions proposed comply with trade fair regulations.

The awarded company will submit, if requested, the complete project for the Spain Pavilion to the fair organization for approval and authorization within the deadline established by the fair.



For this purpose, the Department of Trade Fair Architecture of ICEX will provide, sufficiently in advance, the final plan of the Spain Pavilion, the list of companies participating in the fair and the regulations of the Trade Fair Organization.

The awarded company shall be obliged to comply with any instructions, corrections and modifications that ICEX may send it, both during the design phase and during the assembly of the Spain Pavilion. Likewise, the awarded company shall accept to work jointly and in coordination with the ICEX team.

ICEX reserves the right to inspect and control the quality of the finishes and the manufacturing process of all the materials to be used in the assembly of the Spain Pavilion as many times as it deems necessary. The awarded company shall comply with all guidelines established by ICEX as a result of these inspections.

All materials used in the construction of the booths must have the homologation and fireproofing certificates required by the organizers of the event.

The awarded company will provide the necessary maintenance personnel, including an interlocutor with executive capacity to approve the necessary interventions. This personnel must be physically present at the fair for the duration of the event and be able to communicate in Spanish.

The constructor must expressly undertake to supply the number of units and construction elements of the Spain Pavilion requested by ICEX to meet the needs of exhibitors.

The company will bring to the fair a complete cleaning kit for each institutional retail stand, which will include at least a 6-pack of paper rolls, 2 containers of cleaning fluid, 5 cutters.

#### **Environmental and sustainability considerations.**

In order to improve management aimed at sustainability, the environmental impact on the surroundings becomes a relevant variable in ICEX activities as differentiating factors that will be mandatory in this project.

To this end, proposals will be sensitive to environmental protection in order to contribute to the prevention of pollution. Environmental management will be considered a strategic element as a competitive advantage over competitors in order for ICEX to become a reference for the sector.

The awarded company will receive the manuals for the application and use of the aforementioned logos.

#### **18.- OBLIGATIONS WITH ICEX**

- The Bidder undertakes to accept all the specifications contained in these specifications.
- The facilities shall remain at the disposal of ICEX and exhibitors for the duration of the Fair.



- The transport and storage of the materials or decorative elements of the Pavilion shall be at the expense of the company awarded the service, which may use any means of transport.
- The company awarded the contract shall be obliged to comply with any instructions, corrections and modifications that ICEX may send it, provided that they do not entail an exceptional expense, both in the project phase and during the assembly of the Official Pavilion. Likewise, the awarded company shall agree to work jointly and in coordination with the ICEX team.
- ICEX reserves the right to inspect and control the quality of the finishes and the manufacturing process of all materials to be used in the assembly of the Official Pavilion as many times as it deems necessary. The awarded company shall comply with all guidelines established by ICEX as a result of these inspections.
- The awarded company shall provide the necessary maintenance personnel, including an interlocutor with executive capacity to approve the necessary interventions. This personnel must be physically present at the fair for the duration of the fair and be able to communicate in English and/or Spanish.
- The constructor must expressly undertake to supply the number of units and construction elements of the Official Pavilion requested by ICEX to meet exhibitors' needs.
- The attached plans are included for illustrative purposes only. The final stand layout will be provided to the company awarded the contract sufficiently in advance of the event.

#### DOCUMENTATION AND TECHNICAL INFORMATION TO BE PROVIDED BY THE AWARDEE

After the ICEX Department of Architecture has sent the final plan of the pavilion the awarded company must submit the following information within 15 days, unless otherwise agreed by both parties:

- TECHNICAL DOSSIER:

- I. Location plan.
  - II. Architectural plan with dimensions.
  - III. Dimensioned general elevations.
  - IV. Standard booth: elements including the booths (plan, elevation and 3D).
  - V. Infographics of the project.
  - VI. Details of the shelves, show cases and furniture.
  - VII. Dimensions of each exhibitor graphic wall.
  - VIII. Catalog of the basic furniture set included in the booths, dimensioned and accompanied by photos.
- **CATALOGUE OF SERVICES and ADDITIONAL ELEMENTS:** must include photographs, dimensions, description and price of the following elements:
    - ✓ 80cm. diameter white table.
    - ✓ High table
    - ✓ White chair
    - ✓ White high stool

38

EUROPEAN REGIONAL DEVELOPMENT FUND

A WAY TO MAKE EUROPE

This service/activity is eligible for co-financing from the European Regional Development Fund (ERDF).

CSV : GEN-b751-2df2-6497-bb8b-2fc2-0a5e-9045-18ec

DIRECCIÓN DE VALIDACIÓN : <https://sede.administracion.gob.es/pagSedeFront/servicios/consultaCSV.htm>

FIRMANTE(1) : MARIA PEÑA MATEOS | FECHA : 12/07/2023 13:30 | Sin acción específica | Sello de Tiempo: 12/07/2023 13:31



- ✓ Counter with logo on the front
  - ✓ Showcase counter with logo on the front
  - ✓ Wastebasket
  - ✓ Shelf with light
  - ✓ Multiple electrical socket with EU adapter (if required).
  - ✓ 32", 42" or 55" TV with HDMI and USB input + electrical connection and wall installation.
  - ✓ Small refrigerator + 24hr electrical connection.
  - ✓ Large refrigerator + 24hrs electrical connection.
  - ✓ Small freezer + 24hrs electrical connection.
  - ✓ Large freezer + 24hrs electrical connection.
  - ✓ Refrigerated display case + electrical connection 24hrs.
  - ✓ Production and installation of adhesive vinyl graphics or similar (price per m2)
  - ✓ Production and installation of adhesive vinyl graphics or similar (price per m2).
  - ✓ Capsule coffee machine.
- **GRAPHIC PORTFOLIO:** Plan and elevation of each individual stand, outlining all the graphic elements of each of the exhibitors, indicating their position in the general plan.

The awarded company must also provide the following information:

- Contact of the person responsible for the awardee company (e-mail and contact telephone number) so that exhibitors participating in the Spanish Pavilion can send the final graphic artwork and make the pertinent queries and requests.
- Calendar of dates and work procedures.

15 days before the fair, the company awarded the contract will send all the updated dossiers, with the changes made, as well as a list of the extra furniture requested by exhibitors to the Department of Architecture of ICEX.

The awardee must build a section of the project in its facilities one month after signing the contract. The costs of assembly and disassembly of this installation shall be borne by the bidder.

Madrid, on the date shown by signature

The Board of Directors of ICEX (Contracting Authority),  
P.D. (Resolution of 30 September 2021. Official State Gazette - BOE no. 243 of 11.10.2021)

María Peña Mateos  
Chief Executive Officer

ANNEX A: DESIGN OF THE SPANISH PAVILION  
The design of the Spanish pavilion is attached.  
ANNEX B: ICEX's Institutional logos

See *Annex C. Economical Offer*

39

EUROPEAN REGIONAL DEVELOPMENT FUND

A WAY TO MAKE EUROPE

This service/activity is eligible for co-financing from the European Regional Development Fund (ERDF).



## ANNEX 1 – LEGAL DOCUMENTATION TO BE SUBMITTED

Documentation to be submitted by the successful bidder:

- Certificate of Public Liability insurance or a third part risk coverage as per Clause Fourteenth of these Bidding Specifications and in accordance with the requirements settle in the Trade Fair Regulations.

## ANNEX 2 – TECHNICAL DOCUMENTATION TO BE SUBMITTED

Documentation to be submitted by the successful bidder:

- The successful bidder shall submit, 15 days before formalizing the contract, a complete project plan for setting up the trade fair. For this purpose, ICEX shall provide in good time the final layout of the Spanish Pavilion, the list of companies taking part in the trade fair and the regulations of the Trade Fair Organization.

