

CALL FOR A DRESSING TENDER AT THE FOLLOWING TRADE FAIR:

SIAL CANADA 2023

The Economic and Commercial Office of the Embassy of Spain in Toronto in the name of ICEX SPAIN TRADE AND INVESTMENT, E.P.E., (from now ICEX), hereby convenes a tender for the construction, assembly, maintenance and dismantling works of the Pavilion of Spain at the following International Trade Fair:

Trade Fair	Date	Venue	Estimated surface
SIAL CANADA 2023	9-11 May 2023	Energare Center, Toronto, Ontario, Canada	1,200 sqft / 111,50 sqm

Tender bidding specifications (VAT excluded).

ICEX is a Spanish institution based in Spain for all purposes.

The tenders should include a breaking down in which the price offered, and VAT must be clearly described and separated.

ICEX will evaluate the tenders based on the offered prices, excluding taxes.

All tenders must be submitted in \$CAD (CANADIAN DOLLARS) excluding VAT (taxes must be clearly described and separated).

Estimated surface: **1,200.00 sqft / 111.50 sqm.**

The price offered shall be of maximum **124.50 \$CAD/sqft - 1,339.91 \$CAD /sqm**, VAT excluded.

The price tendered by the bidding company for net surface may not exceed **\$CAD 149,400.00** (one hundred forty-nine thousand Canadian Dollars) – **124.50 \$CAD/sqft x 1,200 sqft** –, VAT excluded. Any quotation exceeding this amount will be dismissed.

All tenders and dressing projects must be sent in electronic format **ONLY** to tenders@icex.es **no later than February, 22nd, 2023, 14:00 hrs** Toronto local time.

Toronto, on the date of the electronical signature

ICEX Board of Directors

By Delegation (Resolution of October 30th September 2021 BOE [Official State Gazette] of October 11th, 2021),

Carlos Gómez García
Economic and Commercial Counsellor
Economic and Commercial Office of Spain in Toronto

Susceptible to be co-financed with funds from the European Union.

BIDDING SPECIFICATIONS GOVERNING THIS TENDER

SECTION A- GENERAL TERMS AND CONDITIONS

FIRST. - Object

The object of this Tender is the selection of a Dressing Contractor who shall be awarded the execution of the construction, assembly, maintenance and dismantling works concerning the Pavilion of Spain at the following 2023 trade fair and the purpose of the same is to achieve the best ratio between price and quality, wherefore ICEX is entitled to award the Tender to that Dressing Company which, at its sole judgement and pursuant to the offer submitted, provides the best terms:

Trade Fair	Date	Venue	Estimated surface
SIAL CANADA 2023	9-11 May 2023	Enercare Center, Toronto, Ontario, Canada	1,200 sqft / 111,50 sqm

If the trade fair organization decides to move the date of the show to a new date in 2023, postpone its celebration to 2024, or even cancel 2023 edition so that the show would be held in 2024, it will be understood that the established agreement between the successful Awardee of the tender and ICEX will be valid for the decoration of the Pavilion of Spain at Sial Canada on those new dates.

Consequently, after signing the agreement, the contractor will not start any production work until ICEX gives the appropriate instructions once the definitive fair dates have been set. These instructions will be given sufficiently in advance so that all the works can be accomplished.

SECOND. - Award Procedure

The selection of the awardee company of this Tender shall be conducted, pursuant to the internal regulations of ICEX, and following the application of the criteria which are listed here below, based on the weighted values assigned to each of them.

CRITERIA	MAXIMUM POINTS
<p>C.1. Economic Offer /Budget <u>Economic Offer /Budget must be in Document 3.</u> Most economical offer: maximum score. Rest of the offers: formula to be applied: "points per offer = (most economical offer price / each offer price) X maximum score per criteria"</p>	20

C.2. COVERINGS SYSTEM 6 MATERIALS (WALLS AND FRONTDESKS) Coverings system must be in Document 2 <i>The proposals that do not reach at least 6.50 points in that criteria will be automatically excluded.</i>		13
It will be valuated: FRONTDESKS AND WALLS <ul style="list-style-type: none"> - Type of material, preferable printed fabric or vinyl sheet, individually per exhibitor. (MAX. 7 points) - Simple installation quick and easy to install. (MAX. 4 points) - Easy maintenance - Smooth surface, particularly easy to clean, maintain and repair. (MAX. 2 points) 		
C.3. BOOTH 'S DIVIDING WALLS Booth's diving walls must be in Document 2 <i>The proposals that do not reach at least 10 points in that criteria will be automatically excluded.</i>		20
It will be valuated: <ul style="list-style-type: none"> - Type of TRANSLUCENT material, preferable with easy maintenance - smooth surface, particularly easy to clean, maintain and repair. (MAX. 10 points) - Simple installation quick and easy to install. (MAX. 10 points) 		
C.4. GENERAL LIGHTINGS & OVERHEAD'S SIGNAGE ENLIGHTENMENT General lighting & Overhead's signage enlightenment proposals must be in Document 2. <i>The proposals that do not reach at least 20 points in that criteria will be automatically excluded.</i>		40
Proposal for the enlightenment of walls and Overhead's signage with led system lamps. It will be evaluated:		
The light quantity is as high as possible, preferably within the ranges of 3,500-5,000lx (Max. 10 points)	10	
The design of the luminaires. It will be valuated: <ul style="list-style-type: none"> - Possibility to orient the spotlights, type of luminaire. (Max. 10 points). 	10	
The proposed position of the luminaires, the homogeneity of the lighting. Lighting projects that do not generate shadow areas will be valued (Max. 10 points)	10	
Hanging signs enlightened as dense and bright full as possible. (Max. 10 points)	10	
C.5. ENVIRONMENTAL CRITERIA. Environmental proposal must be in Document 3.		3
The proposal includes materials whose composition is recyclable and respectful of the environment as well as proposals associated with the elimination of single-use materials. (Max. 1.5 points)	YES:1.5 NO:0	
The proposal includes description of the waste policy for deteriorated materials that will no longer be used at the fairs subject to this tender as well as proposals for reuse, recycling, destruction, etc. (Max. 1.5 points)	YES:1.5 NO:0	
C.6. IMPROVEMENT Improvement must be in Document 3 Any improvement that does not involve an additional cost for ICEX nor exhibitors and that is not included above.		4
Backlite wall for ICEX booth.	YES:4 NO:0	
Total		100

Responses C2 to C4, both inclusive, will be scored as follows:

0% of allocated points	Proposal simply states that the bidder can meet some or all the requirements but does not provide information or detail on how they will do so
50% of allocated points	Compliant
75% of allocated points	Fully Compliant
100% of allocated points	Exceeds Requirements

Tiebreaker Criteria.

In the event of a tie in the score obtained by two or more bidders, it will be resolved by applying the social criteria indicated below, in order and referring to the end of the proposal submission period. The supporting documentation of the tiebreaker criteria referred to in this clause will be provided by the bidders at the time the tie occurs, and not beforehand.

- Greater percentage of workers with disabilities or in a situation of social exclusion in the workforce of each of the companies, prioritizing in case of equality, the greater number of permanent workers with disabilities in the workforce, or the greater number of workers included in workforce.
- Lower percentage of temporary contracts in the workforce of each of the companies.
- Greater percentage of women employed in the workforce of each of the companies.
- The tie if the application of the previous criteria had not given rise to a tiebreaker.

ICEX reserves the right to collect information on any incomplete aspects or questions that may arise from the bids submitted by the participating companies. Participating companies must correct the defects by the deadline indicated in each case.

Every Company taking part in the tender shall receive appropriate notice on whether ICEX has decided to award them the Contract or otherwise.

ICEX may consider that no bidders qualify for the award of the tender if following the bids and documents submitted these do not comply with minimum requirements like solvency of the Contractor, the technical project, its suitability or the prices quoted.

ICEX reserves the right to revoke the award at any time if the winning bidder fails to fulfil any of the requirements in the Call for Bids and the Terms and Conditions governing the tender.

The bidder with the highest score will be informed of the award as soon as possible.

THIRD. - Award sum

The price offered by the bidders shall include, among others, all expenses even those regarding fluctuations in exchange rates and cannot be modified during the period of the agreement and, if applicable, its extensions.

The price tendered by the bidding company for net surface may not exceed **\$CAD 149,400.00** (one hundred forty-nine thousand Canadian Dollars – **124.50 \$CAD/sqft x 1,200 sqft –**), VAT excluded.

Any quotation exceeding this amount will be dismissed.

This is an estimated cost; if the Sqft of the Pavilion vary, it will imply a variation of the cost, according to the price per Sqft.

The price per Sqft specified in the tender, may not be varied or amended in any way by the Awardee, during the period of the Contract and following extensions.

The price per Sqft tendered must include all works regarding the construction, assembly, provision and connections of additional mechanisms and devices necessary to make all the equipments work, even those rented by the exhibitors such as refrigerated displays, audiovisuals, etc., maintenance and

disassembly of the Spanish Pavilion, as well as all expense items arising from transport from and to the site where the Fair is held, and the necessary equipment for assembling and dismantling the Pavilion, warehousing and transport of loads within the Fair and rental of whatever other services are required within the Fair in order to execute the Agreement.

The price must also include:

- Set up, maintenance and dismantling labours, supervisor labours, Truckage charges, disposal costs, management fees, or the production and hanging labour (installation and dismantling) of all the hanging elements if required.

No additional extra costs will be accepted.

The price does not include:

Handling Charges/Drayage. The amount of the Drayage charges should be calculated separately, and the tenderer must submit a Drayage an estimate together with the tender.

Electricity and Power supply. All electrical and pipe installations work from source of supply at the exhibition (even if these works must be carried out solely by the Organiser's official contractor).

Wi-Fi service for the entire Pavilion.

FOURTH. – Estimated Contract Value

The **estimated value of the contract** considers the value of the first contract and the value of two (2) possible extensions.

According to the latter, **the estimated total contract value** of these contract is **\$CAD 463,140,00 (VAT excluded)**, which includes the following amounts:

- Main contract maximum budget: **(\$CAD 149,400.00).**
- First extension maximum budget: **((\$CAD 149,400.00).**
- Second extension maximum budget: **((\$CAD 149,400.00).**
- Modifications (máx. 10%): **((\$CAD 14,940.00).**

FIFTH. - Price and payment arrangement

The total price will be paid, following submission of the appropriate invoice, in the terms that ICEX and the Awardee Company agree.

ICEX will satisfy the amount specified in the tender for the main contract in instalments. The first instalment of 50% will be paid upon contract signing and Contractor's presentation of the corresponding invoice.

The second instalment corresponding to the remaining 50% of the total price agreed will be paid within thirty (30) days after the conclusion of the fair upon presentation of the corresponding invoice, issued in \$CAD, once the penalties, if any, have been deducted.

Administrative requirements for billing:

- Invoicing details:

All invoices must be billed to:
ICEX España Exportación e Inversiones, E.P.E.
Paseo de la Castellana 278
E-28046 Madrid (Spain)

And dispatched to:
ICEX España Exportación e Inversiones, E.P.E.
Economic and Commercial Office

Susceptible to be co-financed with funds from the European Union.

170 University Avenue
Floor 7th, Suite 700
Toronto (Ontario), Canada
VAT number: ESQ - 2891001F (ICEX is VAT registered in Spain)

SIXTH. - Procedure

This briefing will be circulated to multiple Companies, and will be published on the Trade Commission of Spain's portal link : <https://www.icex.es/es/quienes-somos/donde-estamos/red-exterior-de-comercio/CA/inicio>

The Companies interested in bidding may contact ICEX (tenders@icex.es) with any questions about the brief up February 20th, 2023, at 10:00 AM Toronto Time.

Please note that any expenditure incurred by candidate Companies in the preparation of the proposals presentation and quotes will be at the expense of those companies involved. Submission of the offer will not generate any fees or reimbursement of any type of expenses.

Submission of an offer and participation in this tender implies the Company express acceptance of all the points contained in this briefing.

The proposal needs to be sent via email to tenders@icex.es February 22nd, 2023, at 14:00 PM Toronto Time.

All files should not exceed 4mb in size if sent as attachment; should files be larger, use a file transfer service, which you have verified works.

The proposal will need to be presented in English, electronically as a pdf and where appropriate, use Excel for numbers.

All competing Companies submitting a proposal should be aware that ICEX Legal Services will review the documentation submitted to ensure that they comply with the requirements of this brief.

After verifying compliance with the Company requirements (see Document 1), the technical offer (work proposal see Document 2) will be reviewed and evaluated. Once the evaluation scores have been assigned to the technical proposal, the economic offer and automatic criteria (Document 3) will be opened and evaluated. **The price contained in the economic offer will not be known until that moment.**

A decision will be made within an estimated period of 4 (four) weeks from the published proposal due date. The decision will be officially notified via email, to enable the selected agency to begin work promptly.

Proposals not submitted within the deadline will be excluded.

Non-compliance with any of the requirements established in the present briefing will result in the disqualification of the Company concerned.

Proposal submission must be divided into three (3) separate documents detailed as follows:

All the documentation shall be submitted **only** in **ELECTRONIC FORMAT**.

- Document 1: LEGAL DOCUMENTATION TO BE SUBMITTED

The Tenders shall provide detailed information about their companies with reference to the following items:

- Legal status, structure, size (turnover, number of employees).
- All competing bidders will be required to provide a solvency report in order to proof that the annual volume of business, referred to the best exercise within the last three available depending on the dates of constitution or start of activities of the bidder and submission of offers, is equal to or greater than **\$CAD 149,400.00**.

Susceptible to be co-financed with funds from the European Union.

- Mention of other dressing projects in which they have been involved in the last three years, with special stress on dressing projects for National Pavilion at Trade Fairs.
- As well as a Letter of acceptance signed by a legal representative of the company whereby, they accept each and every term and condition set out in this Call for a Dressing Tender and its Bidding Specifications.

- Document 2: TECHNICAL DOCUMENTATION TO BE SUBMITTED

Documentation to be submitted by the bidders:

The offer must necessarily include:

- Plans of the proposal, including ground plans elevations with dimensions, and overall perspectives to show a proper comprehension of the project.
- Project specifications, including finishes, materials and building processes. These specifications must take into consideration the aspects indicated in the “Specifications of Works”.
- Specifications and details of the overhead’s structure enlightenment. Specifications and technical details, including luxes and temperature of light data, design, and type of the luminaires, colour and adjustability of the spotlights.
- General Lightings in booths. Specifications and technical details, including luxes and temperature of light data, design, and type of the luminaires, colour and adjustability of the spotlights.
- Details and information concerning the Improvement related to the Led screen in Gastro Area.
- Specifications of the Environmental proposed project.
- Perspectives and/or 3D computer graphics to show a proper comprehension of the project.
- Layout with the proposed position of the luminaires in walls.

The offer should include information to enable tenders to be evaluated in accordance with the criteria set out above.

The information provide in Document 2 does not clash with the information required in Document 3. The tenderer must avoid introducing in Document 2 any reference to the prices.

- Document 3: ECONOMICAL PROPOSAL, CRITERIA C.4. ENVIRONMENTAL CRITERIA & CRITERIA C.5. IMPROVEMENT

Documentation to be submitted by the bidders:

ECONOMICAL PROPOSAL

Economic proposal must be in \$CAD (Canadian Dollar).

- Breakdown of the total cost in estimated percentage:
 - Previous works-Production (booths, electricals, water, etc): %
 - Site works (set up and dismantling): %
 - Transportation, load and unload service: %
 - Management and operation services fees: %
- Detailed budget by chapter and by item, stating the unit prices.
- **Handling Charges/Drayage estimate.** Calculated separately; not included in the tender price).
- **Electricity and Power supply.** All electrical and pipe installations work from source of supply at the exhibition (even if these works must be carried out solely by the Organiser’s official contractor).
- **Wi-Fi service for the entire Pavilion.** Calculated separately; not included in the tender price
- Annex C, Economical Offer duly fulfilled.

AUTOMATIC CRITERIA: C.4. Environmental Criteria & C.5. Improvement Criteria

Annex D duly fulfilled.

Susceptible to be co-financed with funds from the European Union.

ICEX will evaluate tenders based on the offered prices, VAT excluded.

The tenders should include a breakdown in which the price offered, and taxes are clearly separated.

Proposals exceeding the maximum available budget **\$CAD 149,400.00**, taxes excluded, will not be considered.

SEVENTH. -Entering into an Agreement

The legal relationship between the successful Awardee of the tender and ICEX shall be recorded following the execution of a Contract. Prior the signing of this Contract, the Awardee must submit within the terms established for the same, the documentation foreseen in the Schedule of these Bidding Specifications (Annex 1 and Annex 2).

EIGHTH. – Procurement Board

Appointed members of the Procurement Board for purposes of this tender will be:

President	María Naranjo	Food Industry Director
Substitute	Salomé Martínez	Food Industry Assistant Director
Member	Salomé Martínez	Food Industry Assistant Director
Substitute	Dolores Mestre	Architecture department Manager
Member	Pilar Randolph	Director Food & Wines from Spain. Trade Commission of Spain in Toronto
Substitute	Juan Francisco Iglesias	Associate Director-Wines from Spain. Trade Commission of Spain Toronto
Member	Diana Vázquez	Head of Food & Beverages Department
Substitute	Gemma Cabot	Area Manager, Food & Beverages Department
Secretary	Pedro Patiño	Head of Procurement Department
Substitute	Isabel Arias	Member of the Procurement Department.

NINETH. – Extension of the contract

In order to uphold the institutional image of Spain at International Trade Shows or Fairs, ICEX hereby reserves the right to extend the contract signed with the Awardee for a maximum of the following two (2) editions of the Trade Fair regardless the date of execution without convening a new tender.

The general terms and conditions of the Bidding Specifications governing this Tender shall apply to the extension.

TENTH. – Modification of the contract

Once the contract has been formalized, the modifications considered necessary for its correct execution may be agreed, as long as they do not alter the global nature of the initial contract or imply a substantial modification. For these purposes, those whose cost implies a variation in the contract price of more than 10% will be considered a substantial modification.

Possible changes in the contract price may be due to a change in the fair location or to new functionalities in the program of needs and / or equipment of the institutional stand or company stands, the inclusion of elements that reinforce the signage at height, which it may be necessary to introduce in this or the next two (2) editions of this fair if the contract is extended.

In this case, the successful tenderer will provide in writing, at the request of ICEX, the technical, economic and other conditions, before carrying out any modification to the contract. The modification must be previously approved by ICEX and formalized in the corresponding contract.

ELEVENTH. – Force Majeure or restrictions imposed by the Fair Ground Authorities

The successful Awardee of the tender and ICEX will not be responsible for the damages and losses caused to the other party for delays or breaches of the contract that bring their cause in cases of *force majeure* or restrictions imposed by the Fair Ground Authorities. The duties of this contract will be considered suspended while the situation of *force majeure* or trade fair restriction lasts, and the parties will try to reach an agreement in good faith that benefits their respective interests as much as possible. In any case, the party that has knowledge of these facts must inform the other as soon as possible so that said duties are suspended or that the measures deemed appropriate are adopted. If the cause of *Force Majeure* or trade fair restriction extends in time until 2024, either party will be entitled to request the termination of the contract without having to indemnify the other party for it.

TWELFTH. – Cancellation or postponement of the fair

In the event that the Tradeshow is not held in 2023 or 2024, or the Pavilion is cancelled in 2023 and 2024, ICEX shall solely satisfy the expenses incurred by the Contractor as from the date of award of this contract (and in connection with the same) until the date of formal notice of this circumstance by ICEX. In order to be reimbursed, the Contractor shall previously submit all documentary invoices of the expenses incurred up to that date. In the same way, the Contractor shall reimburse ICEX the amount advanced of the expenses not incurred.

THIRTEENTH. -Execution of the contract

ICEX Project Manager is ultimately responsible for setting up the Pavilion. In the absence thereof, the Coordinator or Manager of the Pavilion will have ultimate responsibility. Any specific requests made by the exhibiting companies shall be responded to after consulting Project Management. The successful bidder shall not, under any circumstances, respond directly to oral requests, which must be addressed to: toronto@comercio.mineco.es

All construction, assembly and dressing work, in connection with the Pavilion, must be completed twelve (12) hours before the Trade Fair Opening at latest except in the event of force majeure or restrictions imposed by the Fairground Authorities. The last day of such works shall be devoted to cleaning tasks in general and attention to stands. The Pavilion must be completely clean one (1) hour before the Trade Fair opening.

All works must be conducted pursuant to the technical specifications set out in these bidding specifications (Section B) and with adequate materials/furniture and finish, whereby faulty or low-quality materials shall not be acceptable.

The Awardee is likewise obliged to dismantle the stands within the term and provisions contemplated in the Regulations of the Enclosure, as well to the instructions given by ICEX or its representatives at the Trade Fair.

FOURTEENTH. – Obligations of the Contractor

The Contractor shall be responsible for compliance of all technical regulations established by the Trade Fair Regulations, and to submit them layouts needed for approval as well as for the payment of the deposits asked by Organisers to allow the works at Exhibition Hall that have to be included in the Tender price.

The Contractor shall avail itself of the necessary human and technical resources in order to meet its obligations. In the event that the Contractor subcontracts any of the works herein assigned to the latter, only the Contractor shall be held liable to ICEX, without recourse to the subcontracting company.

Likewise, the provisioning of services and obtaining the necessary permits and authorisations and insurance required to undertake the assembly, dressing and dismantling works concerning the Pavilion shall be fully met by the Contractor. In any event, the Awardee must take out a civil liability insurance

which covers any claims filed following personal or property damages or losses suffered by workers, exhibitors, visitors or any other person during, or as a consequence, of the assembly, dressing or dismantling of the Pavilion. All costs arising from these items must be included in tenderer's price offer.

The Contractor hereby undertakes that throughout the assembly process of the Pavilion, it shall appoint a person vested with sufficient capacity to order the changes which may be required following unforeseen or uncomfortable circumstances during the assembly process.

The Contractor shall likewise provide ICEX with the number of workers required in order to help the exhibitors during the afternoon previous to the Trade Fair inauguration and the morning in which the Trade Fair has been inaugurated and at least two (2) members of its "in-house" personnel to ensure "on-site" proper maintenance of the Pavilion throughout the Tradeshow.

ICEX is entitled to amend or cancel specific items and in that event the Contractor shall be notified of the foregoing sufficiently in advance.

FIFTEENTH. – Subcontracting

The contractor will not be allowed to subcontract any of the works assigned hereof, unless ICEX previous authorization. In that event, exclusively the contractor will be held liable before ICEX for the works or omissions of the subcontracted company.

SIXTEENTH. – Ownership of the designs

All designs used in the Spanish Pavilion are the proprietary ownership of the ICEX, and may not be reproduced, copied or used by the Contractor for any other clients or projects.

SEVENTEENTH. – Health and Safety at Work

The Awardee shall be responsible for compliance of all industrial, health and safety regulations established by the legislation of the country in which the Trade Fair is held and by the Regulations of the Enclosure.

EIGHTEENTH. – Penalties

18.1 Assembly

ICEX may impose penalties following an inadequate or poor finish, the use of faulty or badly preserved materials, and in general, for any assembly deficiencies. Such penalties shall be reckoned pro rata to the damages caused.

Any delivery delay on the agreed schedule (12 hrs before each one of the Trade fair Openings) shall entail a 4% penalty on the total amount of the Agreement for each of the first three (3) hours or fraction of an hour, with an additional 10% surcharge from the fourth to the sixth hour. Should the delay exceed six (6) hours, ICEX shall study the appropriate penalty thereon, which in no event shall be more than the result of applying 50% to the total consideration of the Agreement.

In the event that the works are not completed when the opening of the Fair takes place, ICEX may, notwithstanding the penalties foreseen in the foregoing paragraph, claim damages from the Contractor (likewise referred to as the Awardee).

When delay in completion of works is due to any breach of the Trade Fair Regulations, the penalty system abovementioned shall be enforced.

If all the required elements of the stands are not made available to the participants in due time and manner, ICEX is entitled to apply the penalties it deems appropriate, and ICEX reserves the right to lease such elements to third parties.

18.2 Dismantling

ICEX may establish penalties in the event of an inadequate dismantling and withdrawal of the elements used in connection with the decoration of the Pavilion, pursuant to the Fair Grounds Regulations thereon pro rata to the damages caused.

Breach of the dismantling schedule as set out in the Fair Grounds Regulations shall entail the application of a penalty to be determined by ICEX which in no event shall be less than 10% of the aggregate consideration for the Contract.

NINETEENTH. – Termination

ICEX is entitled to terminate the Contract following a breach of the Contractor of any of its contractual obligations, in addition to any claim for damages and legal remedies which may be available.

TWENTIETH. – Applicable legislation

Dressing works shall be governed by the terms of the contract entered into between the awardee Contractor Company and by the tender specifications, which shall be incorporated to the same, and in default of the above, the Spanish legislation shall be applicable.

TWENTY-FIRST. – Jurisdiction

In order to solve any dispute, disagreement, issue or claim which may arise from the performance or construction of the Contract executed with the successful Awardee of this tender, the matter will be referred to the ordinary Courts. The parties, renouncing the jurisdiction that may correspond, expressly submit to the Courts of the city of Madrid.

Toronto, on the date of the electronical signature

ICEX Board of Directors

By Delegation (Resolution of October 30th September 2021 BOE [Official State Gazette] of October 11th, 2021),

Carlos Gómez García
Economic and Commercial Counsellor
Economic and Commercial Office of Spain in Toronto

BIDDING SPECIFICATIONS GOVERNING THIS TENDER

SECTION B – TECHNICAL SPECIFICATIONS

Estimated total Surface: 1,200.00 sqft / 111.50 sqm

SPECIFICATIONS OF WORKS

The Awardee shall be responsible for compliance of all technical regulations established by the Trade Fair Regulations, and to submit them layouts needed for approval as well as for the payment of the deposits asked by Organisers to allow the works at Exhibition Hall that have to be included in the Tender price.

All materials used in the stand construction must be properly fireproofed in accordance with local regulations.

The plans attached are only indicative. A final layout will be sent, if necessary, to the awardee in good time before the dates of the Show. The modifications will be made by the contractor at no extra cost.

The tender must include:

- Plans of the proposal, including ground plans elevations with dimensions, and overall perspectives to show a proper comprehension of the project.
- Project specifications, including finishes, materials and building processes. These specifications must take into consideration the aspects indicated in the “Specifications of Works”.
- Construction details of all the main elements of the project, with sections, front views and perspectives that allow a clearly understanding of the proposed solutions: lighting systems.
- Specifications and details of the overhead’s structure enlightenment. Specifications and technical details, including luxes and temperature of light data, design, and type of the luminaires, colour and adjustability of the spotlights.
- General Lightings in booths. Specifications and technical details, including luxes and temperature of light data, design, and type of the luminaires, colour and adjustability of the spotlights.
- Details and information concerning Improvements.
- Specifications of the Environmental proposed project.
- Perspectives and/or 3D computer graphics to show a proper comprehension of the project.
- Layout with the proposed position of the luminaires in walls.
- Photographs of the furniture.
- Perspectives and/or 3D computer graphics to show a proper comprehension of the project.

DESIGN AND CONSTRUCTION

The Pavilion of Spain project has the intention to enhance the presence and image of Spain and the Spanish firms, and to serve as a platform for every exhibiting company to freely customize its image inside its own space.

FLOORING

The floor of EXHIBITOR’S BOOTHS will be covered with carpet **on foam padding**. The colour of the carpet will be **white**.

All wires, pipes or any other installation items have to be concealed under the carpet, inside the foam padding.

In order to protect the floor materials, visqueen or similar cover will have to be installed over them prior to installation of the exhibits. Works to remove the cover before the inauguration must be included in the overall price.

Carpet has to be thick, (American standard) not European standard.

To protect the inlays, visqueen or similar cover will have to be installed over them prior to installation of the exhibits. Works to remove the cover before the inauguration must be included in the overall price, as well as works to remove all floorings after the show closes and all relevant work costs related to the floorings.

BOOTH'S STRUCTURE

The Pavilion has to be built using continuous structure system, creating a seamless white wall. All wires, pipes or any other installation items have to be concealed.

The space will have one separation display for each booth made with **translucent Screens (100% transparency)**. There will be one stand per participating company and one official booth for ICEX. The stand space will be adapted to the number of companies.

Backwalls

- All backwalls will be built in a continuous look with no interruptions due to Inner structure. Frames and structures should not be seen.
- The Construction system of walls allows to stick in-prints graphics on a smooth and continuous surface, with no interruptions.

The backwalls will be 2.438 m (8,00 feet) high.

Its lower part of 2,00 m (6.56 feet) H will be prepared for printing out in its entirety, as a whole graphic, including the built-in closets doors.

Its upper part of 0.438 m (1.64 feet) H (wall in white colour) will be reserved for:

Exhibitor's lettering
Regional Group Lettering (only for Regional Groups if appropriate)
Exhibitor's logo
Booth number
E Spain logo

If a **Spanish Region** will participate as exhibitor in the Spanish Pavilion, its top off ID wall should be painted in the corresponding corporate colour. In this case the client will provide the required information.

The finishing of these walls will be prepared for printing out in its entirety, as a whole graphic. If the exhibitor does not require to use the walls of their booth with images (total or partially) then the finishing of the walls will be solved in white colour (laminated, paper, vinyl, fabric, etc.).

On top of Backwalls the proposal must **accommodate the enlightenment**. Powerful luminaires system in LED lights with homogeneous enlightenment result. This enlightenment is very important to get a bright and powerful illumination on the walls and first level shelves.

Storerooms/built-in closets

The construction will have **built-in closets** (wall cabinets), organised all along the backwalls with a depth of 80cm (2.62 feet) and 2m (6.56 feet) of height with interior shelving display.

Junctions and knobs of the door's cabinets won't interfere of the full use of the wall for graphics.

Susceptible to be co-financed with funds from the European Union.

Clothes hooks are necessary on the interior doors.

Translucent Screens between booths

The design project has been conceived to have a continuous perspective through the booths. For that purpose, the dividing walls between booths will be raised in translucent materials (100% transparency) with a circular shaped radio 45 cm (17 inches) snow vinyl.

Translucent screens will be raised on top of a support base (to create full stability). The maximum height will be 1.219 m (4 feet).

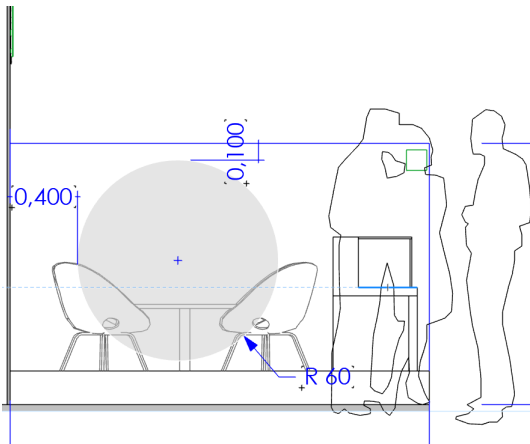

BOOTH'S GRAPHICS

Each exhibitor will have:

- **A commercial printed image mounted on backwalls.**

The tender will include the production and installation of graphic material, which will be carried out on the back walls of the booths in high quality adhesive cut out vinyls. Rigid or semi-flexible supports will not be accepted for the graphics, whose installation will be the superposition on the walls. The graphic will cover the entire wall, in height and length, including the warehouse door panel, which will not have visible opening knobs to avoid highlights in the graphic's vision.

The tenderer will be responsible for attending, supervising and coordinating the reception of the final arts of the graphics that each exhibitor will send them for their subsequent production and installation.

The image will be previously selected by every firm who will send it to the awardee company. Each exhibitor will be responsible of sending their final artwork, and the awardee company will ensure maximum printing quality of the forementioned artwork.

- **Logo** (for the upper part of the backwall booth and for the glass showcase front).

The awardee company will be responsible of coordinating and recollected the artworks from the exhibitors in order to work on the final layouts, final prints on the walls, and correct installation of the aforementioned artworks.



Awardee company will be responsible of the production of all graphic material as well as the necessary workforce for their correct positioning. The awardee company will submit for approval a sample before printing all the graphics.

Susceptible to be co-financed with funds from the European Union.

The size of the final prints will be conformed and adapted to walls sizes.

The aforementioned images will be appropriately enlightened through the powerful luminaires system in LED lights from the upper part of the wall.

BOOTH'S FURNITURE

In order to estimate the furniture that should be included in the quotation, the tenderer must take into account the following standard furniture that all the exhibitors may request without additional charge:

Booth size	Low Glass Showcase 100 + Sloping wedge inside showcase	Shelves (100*25cm)	Table 80	Chairs
100 sqft (9.29 sqm)	1	3	1	4
From 101sqft to 200 sqft (9,50 sqm-18.58 sqm)	2	6	2	8
From 387 sqft (36,00 sqm)	4	9	4	16

In addition, for every exhibitor, regardless of the size of the booth, the tender should include without additional charge the following:

- 1 Spitoon and 1 ice bucket wine (for two bottles) for Wineries exhibiting.
- 1 wastebin.
- Storage closet, with:
 - Wall Clothes rack.
 - At least 4 Shelves.
 - All built-in closet doors will have lock and key (2 per built-in closet plus master key).
- Electrical connections /sockets:
 - 1 Standard double socket/500Watts within the exhibition area.
 - 1 x 24hrs/ 500Watts socket within the storeroom if necessary.

All exhibitors who need an electrical equipment to exhibit their products (refrigerated, freezer, coffee machine, etc.) will have an additional 24h/1.000W power socket without extracharge.

- Lettering, booth number & logo. Each exhibitor will have:
 - 1 Company name in dark grey vinyl cut-out typography *Helvetica Neue* in capital letters. Location: booth's Backwall top.
 - 1 Stand number. Location: Top of backwalls.
 - Exhibitor's logos 35x35cm (1.15 x 1.15 feet) cm vinyl cut-out.
 - Location: Top of backwalls and show cases fronts.
 - QR code. The image of the QR code of each company and also the Economic and Commercial office will also be included in the desks.

Following is the description of the main furniture displays:

- Low glass showcase unit (LGS)

Size: ap. 100L*50D*100H cm (3.28L*1.64D*3.28H Feet).

The upper part of this piece of furniture will allocate a glass show window

The lower part will have a full space to store, inner shelf and lockable doors (2 per storeroom plus master key).

Finishing will be in White colour.

A supplementary wedge to be placed within the glass show window as exhibiting support supplement will be provided.

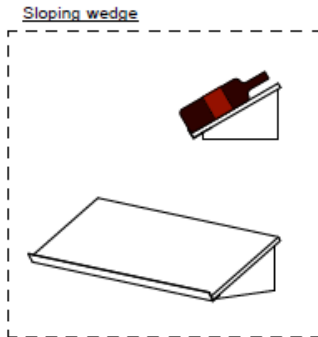

- **Shelves for exhibition**

These pieces of furniture will be weight resistant, made in a very good and aesthetic material and finishing, especially the wall fitting system (**preferably hidden system**).

The minimum dimensions for these shelves should be 100cm L X 25 cm D (3.28L*0.82 Feet). Shelves have to support at least 20 kg/shelf.

The net height between shelves will be the same for all the booths: **38 cm** (1.25 feet).

OVERHEAD'S INSTITUTIONAL IDENTIFICATION (SPAIN AND REGIONAL GROUPS).

The cubic Content Rule from Organizers manual applies to Peninsula, Island booths and linear booth for International Pavilions. This rule allows display material to rise a maximum height of 16 ft (4.88 m) throughout the confines of the booth.

The design pretends to highlight the overhead's view of the Spain's national identification raising an ID structure, arranged in series, reaching the maximum permitted height, so as to improve the visibility as well as to identify SPAIN, by using graphics panels on every side of each one of them, distributed in different heights to get a discontinuous look.

The panel series will go over the booth's areas from side to side, so the final length will be decided depending on the maximum size of the rented spaces.

Use of these overhead panels:

For Spain National colours flag ID (yellow and red). Panels will be printed in two sides.

For sectorial food images. It will be printed in two sides.

The overhead panels will be enlightened on every side. Construction details to be sent by the Tenderer.

For the Identification with Spain letterings front lightened. The word SPAIN will appear in English and Spanish. The panels will be constructed in light system (metal frame, wooden frame, etc).

The awardee will be responsible of printing the images.

ICEX will provide to the awardee company the artworks, in order to work on the final layouts, final prints, and correct installation of the aforementioned artworks.

Susceptible to be co-financed with funds from the European Union.

The Awardee company will be responsible of the production of all graphic material as well as the necessary workforce for their correct positioning. The awardee company will submit for approval a sample to Icx before printing all the graphics.

INSTITUTIONAL SIGN HUNG.

Estimated sets: 4

The objective of this signage is to highlight the location of the Pavilion of SPAIN along the main aisles of the Show.

We propose a circular overhead double printed structure of at maximum 20' Ø x 3' (H) for the exterior unit, dramatically enlightened.

Both sides will show the same red background in both sides. The exterior side will be printed with Spain's letters all along its length on the exterior side, while the interior unit will be printed in its interior side. The background will be pantone red 485C and the typography will be attached in Annex B

The bid price must include hanging, truss and enlightenment.



The contractor will be in charge of (and will be held responsible for) the hanging service fittings and ordering of the Official supplier. All hanging costs must be included in the Tender.

INSTITUTIONAL AREAS

ICEX's booth. The booth prototype will follow the provision of:

- **One (1) Counter** (2 m long) for 2 attendants furnished with shelves and lateral hanging hook. The lower part will have a space to store (shelves) that won't cause any annoyance with the attendants seating position on the high stools. Enlightenment with leds lamps system (decorative). With:
 - 3 High stools
 - 2 paper bins.
 - 1 x double standard socket.
- **Open area** with:
 - 85"led screen TV (with USB connection).
 - 2 x 2 double standard sockets on the open area.
 - 1 set of 1 table+ 4 chairs.
- **Internet Area**

Susceptible to be co-financed with funds from the European Union.

- One Counter for 1 computer (laptop) with 1 stool.
 - The provision of 1 Computer (laptop) completed connected and prepared to work with (power supply, connected with the printer and with ADSL Internet service working).
 - Supply of Internet (ADSL) network with two connections: one connection for the aforementioned computer, and the second one available for an additional computer (coming from exhibitors).
 - One printer/photocopy machine (multifunction), conveniently connected with the requested Laptop, ready to work with.
 - All the necessary electrical connections for the aforementioned equipments
- **In-built cabinet** with reinforced shelves, wall clothes hooks.
 - 1 Fridge.
 - 1 lockable cupboard.
 - Capsule ´s Coffee machine (provision of capsules, sugar, milk capsules and wood spoons).

All the necessary electrical connections, for the aforementioned equipments, will be needed.

- **Graphics on walls:** Directory, Foods & Wines from Spain General Graphics, etc.

LIGHTINGS

General lighting in booths

- **Booth ´s backwalls**
On top of Backwalls there will be a powerful and professional enlightenment. **Led** Luminaires system preferentially.

Overhead Structure ´s lighting

The overhead panels will be frontlighted on every side with LED technology. Powerful system of lamps required to reach the best brightness of the pieces.

The overhead panels will have to be perfectly lit (LED highly recommended) to get an impressive and highly bright image of all graphics.

ENVIRONMENTAL CRITERIA

In order to improve management aimed at sustainability, the environmental impact on the environment becomes a relevant variable in ICEX activities as differentiating factors.

In that way, the proposals will be sensitive to the protection of the environment to contribute to the prevention of pollution. Environmental management will be considered a strategic element as a competitive advantage over competitors so that ICEX becomes a reference for the sector.

ELECTRICITY AND LIGHTING

Please refer Technical services Manual for details regarding Organiser ´s appointed official contractors for various services, so as to ensure a more efficient and regulated build-up and dismantling.

The contractor will be in charge of (and will be held responsible for) the electrical fittings and ordering of the general supply power. The Contractor will carry out all work related with power installations starting from the general supply points and will provide all the necessary spotlights, display lighting general lighting, power points and labour. The contractor will also carry out subsequent procedures with the official contractors and coordinate with them.

The price does not include Electricity and Power supply. All electrical and pipe installations work from source of supply at the exhibition (even if these works must be carried out solely by the Organiser´s official contractor).

The amount of the **Electricity and Power supply** installation and service charges should be calculated separately, and the tenderer must submit an **Electricity and Power supply estimate** together with the tender.

The contractor will also carry out all subsequent procedures with the official contractors and coordinate with them.

Beyond the aforementioned main electrical works, the labour to install, assemble, connect and hang all the lights **must be included in the tender**.

WIFI service for the Pavilion

The Contractor will be in charge of taking the provision and installation of WI FI service for the entire Pavilion.

The price does not include Wi-Fi service for the entire Pavilion. The amount of the Wi-Fi installation and service charges should be calculated separately, and the tenderer must submit a Wi-Fi an estimate together with the tender.

The description of that service (including Wifi routers units and range) will be necessary.

MISCELLANEOUS

Cleaning

The Pavilion must be completely cleaned 1 (on)e hour before the opening of the Trade Fair, being this whole responsibility of the Contractor.

The successful bidder shall also be responsible for compliance of all regulations established by the Trade Fair Regulations regarding any dumpsters needed for the removal of any materials, as well as for the removal of the materials itself after the closing of the Trade Fair. This must be included in the overall price.

Miscellaneous

Graphics produced by the contractor shall be included in the Tender. Final artworks to be provided by ICEX.

The successful bidder will provide a first aid kit for the Spanish Pavilion.

The successful bidder will supply all fire extinguishers required to comply with the relevant trade fair regulations. They will all be certified as full and carry the expiry date.

Furthermore, the decorator undertakes to pay any fee arising from performance of work outside hours at the trade fair, and any other fee that the trade fair organization might request, both at the beginning and at the end of the trade fair which are not included in these specifications.

All items relating to the electricity, water supply and drains must be hidden and, in passageways, have indicating signs and be protected.

Layout plans are only indicative. Tenderers should work on a fictional spaces to develop the proposals. Layouts of the Fairs are not still available.

A final layout will be sent, if necessary, to the successful bidder in good time before the dates of the Show.

The modifications will be built by the contractor at no extra cost.

See **Annex A. SIAL CANADA 2023_SPAIN'S DESIGN GUIDELINES**

See **Annex B. INSTITUTIONAL LOGOS**

See **Annex C. Economical Offer**

See Annex D. Automatic Criteria. C5 (Environmental criteria) and C6 (Improvement criteria)

Toronto, on the date of the electronic signature

ICEX Board of Directors

By Delegation (Resolution of October 30th September 2021 BOE [Official State Gazette] of October 11th, 2021),

Carlos Gómez García
Economic and Commercial Counsellor
Economic and Commercial Office of Spain in Toronto

ANNEX 1 – LEGAL DOCUMENTATION TO BE SUBMITTED

Documentation to be submitted by the successful bidder:

- Certificate of Public Liability insurance or a third part risk coverage as per Clause Fourteenth of these Bidding Specifications and in accordance with the requirements settle in the Trade Fair Regulations.

ANNEX 2 – TECHNICAL DOCUMENTATION TO BE SUBMITTED

Documentation to be submitted by the successful bidder:

The successful bidder shall submit, 15 days before formalizing the contract, a complete project plan for setting up the trade fair. For this purpose, ICEX shall provide in good time the final layout of the Spanish Pavilion, the list of companies taking part in the trade fair and the regulations of the Trade Fair Organization.