

CALL FOR A DRESSING TENDER AT THE FOLLOWING TRADE FAIR:
SIAL CANADA 2025

The Economic and Commercial Office of the Embassy of Spain in Toronto in the name of ICEX SPAIN TRADE AND INVESTMENT, E.P.E., (from now ICEX), hereby convenes a tender for the construction, assembly, maintenance, and dismantling works of the Pavilion of Spain at the following International Trade Fair:

Trade Fair	Date	Venue	Estimated surface
SIAL CANADA 2025	April 29 - May 1, 2025	Enercare Centre, Toronto, Canada	1,200 sqft / 111.48 sqm

Tender bidding specifications (VAT excluded).

If due to the nationality of the company, taxes associated with the execution of this contract are not applicable, please indicate expressly in the tender (Document 3).

ICEX is a Spanish institution based in Spain for all purposes.

The tenders should include a breaking down in which the price offered, and VAT must be clearly described and separated.

ICEX will evaluate the tenders based on the offered prices, excluding VAT.

All tenders must be submitted in CAD (*Canadian dollar*) excluding VAT or other taxes (taxes must be clearly described and separated).

Estimated surface: **1,200 sqft / 111.48 Sqm.**

The price offered shall be of maximum **CAD 165/sqft**, VAT excluded.

The price tendered by the bidding company for net surface may not exceed one hundred ninety-eight thousand CAD (**198,000 CAD**) **CAD 165 x 1,200 sqft**, VAT excluded. Any quotation exceeding these amounts will be dismissed.

All tenders and dressing projects must be sent in electronic format **ONLY** to tenders@icex.es no later than **October 3rd, 2024, 10:00 AM** Toronto local time.

Toronto, on the date shown by signature.

ICEX Board of Directors (Contracting Authority),
By Delegation (Resolution of 30th September 2021 BOE [Official State Gazette] no. 243 of
October 11th, 2021),

José Luis Echaniz Cobas
Economic and Commercial Counsellor Trade Commission of Spain in Toronto

BIDDING SPECIFICATIONS GOVERNING THIS TENDER

SECTION A- GENERAL TERMS AND CONDITIONS

FIRST. - Object

The object of this Tender is the selection of a Dressing Contractor who shall be awarded for the execution of the construction, assembly, maintenance and dismantling works concerning the Pavilion of Spain at the following trade fair and the purpose of the same is to achieve the best ratio between price and quality, wherefore ICEX is entitled to award the Tender to that Dressing Company which, at its sole judgement and pursuant to the offer submitted, provides the best terms:

Trade Fair	Date	Venue	Estimated surface
SIAL CANADA 2025	April 29 - May 1, 2025	Enercare Centre, Toronto, Canada	1,200 sqft / 111.48 sqm

If the trade fair organization decides to move the date of the show to a new date in 2025, postpone its celebration to 2026, or even cancel 2025 edition so that the show would be held in 2026, it will be understood that the established agreement between the successful Awardee of the tender and ICEX will be valid for the decoration of the Pavilion of Spain at **SIAL CANADA** Show on those new dates. The new date of the fair will not affect contract extensions.

Consequently, after signing the agreement, the contractor will not start any production work until ICEX gives the appropriate instructions once the definitive fair dates have been set. These instructions will be given sufficiently in advance so that all the works can be accomplished.

SECOND. - Award Procedure

The selection of the awardee company of this Tender shall be conducted, pursuant to the internal regulations of ICEX, and following the application of the criteria which are listed here below, based on the weighted values assigned to each of them.

CRITERIA	MAXIMUM POINTS
<i>DOCUMENT 3: ECONOMIC OFFER AND AUTOMATIC CRITERIA</i>	32
C.1. Economic Offer /Budget <u>(Economic Offer /Budget must be in Document 3.)</u>	30
Most economical offer: maximum score. Rest of the offers: formula to be applied: "points per offer = (most economical offer price / each offer price) X maximum score per criteria"	MAX: 30
C2.-Environmental criteria <u>(Criterion to be evaluated by automatic criteria must be in Document 3)</u>	2
The proposal includes materials whose composition is recyclable and environmentally friendly, as well as proposals associated with the elimination of single-use materials. Certification of timber and/or forestry products derived from sustainably managed forests - Use of eco-labelled products or other equivalent quality marks - Use of materials from recycling processes. (Max. 2 points)	SI: 2 NO: 0
<i>DOCUMENT 2: CRITERIA TO BE EVALUATED BY MEANS OF A VALUE JUDGMENT</i>	68
C3.-Materials and construction systems <u>(Criterion to be evaluated by means of a value judgment must be in Document 2)</u>	45
Degree of adequacy of the proposal to the aspects described in the Technical Specifications, based on the description of each section requested. See the Technical Specifications for details of aspects to be evaluated. The proposals that do not reach at least the score of 22,5 points in this criterion will be automatically excluded.	

<p><u>It will be valued:</u></p> <p>Structures at height, floors and walls: up to 24 points</p> <ul style="list-style-type: none"> - <u>Type of materials and composition</u> intended for the pieces for identification at height, floors and walls. Both the base structures of the pieces and the final finishes will be valued, so that the pieces have a continuous final surface without visible projections. It will be valued the lightness as well. 10 points maximum. - <u>Mechanization and assembly</u> of the identification structures in height and components of the booths: structures supported on the booths and suspended from the hall's ceiling, floors and walls. It will be valued that the different parts of the construction ensemble arrive at the fairgrounds ready to be assembled in a mechanized and fast way. The economy of time invested in the installation of the parts will be taken into account and, in particular, the assembly of floors, walls and national identification pieces at height will be valued. 10 points maximum. - <u>Type of material and composition destined to the identification of Spain/España corporeal letters, logos, claims and identification of Regional Groups.</u> It will be valued so that its visibility is maximum, and a high degree of luminosity is achieved. 4 points maximum. 	<p>MAX: 24</p>	
<p>Separations between booths: up to 6 points</p> <ul style="list-style-type: none"> - <u>Type of material and composition.</u> The degree of transparency will be evaluated. 2 points maximum - <u>Installation system.</u> It will be valued that it allows a quick and easy handling. 2 maximum points - <u>Level of stability of the piece once assembled.</u> It will be valued that the base is solid, and the transparent pieces are well locked and anchored. 2 maximum points 	<p>MAX: 6</p>	
<p>Graphics on walls: up to 5 points</p> <ul style="list-style-type: none"> - <u>Type of material and composition.</u> Its adaptability to a flat surface (flexibility), the weight of the material and resistance to environmental conditions, especially heat and cold, will be evaluated. 3 points maximum - <u>Placement system that allows quick and easy handling.</u> It will be valued that the system gets a good tensioning of the graphic to avoid wrinkles and misalignments. 1 point maximum. - <u>Printing system</u> that guarantees quality colors and image sharpness. The type of printing inks and their adherence to the base support will be valued. 1 point maximum 	<p>MAX: 5</p>	
<p>Furniture/ Shelves and display cases: up to 10 points</p> <ul style="list-style-type: none"> - <u>Shelves:</u> Placement system that resolves loads greater than 25 kgs without altering the design required in the project, maintaining the anchoring system and light wiring of the concealed shelf. Hidden anchorages that cover the entire thickness of the wall up to almost the entire depth of the shelf, as well as the number of anchor points/shelf and its section, will be valued. 4 points maximum. - <u>Showcases:</u> Glass case opening-closing system. It will be assessed that the case allows a comfortable and easy access to its interior for product placement. The design, quality of the materials, ease of use, good lighting of the showcase will be valued. Maximum 4 points. - <u>Furniture</u> (booth chairs and seating in general) for exhibitor booths and institutional spaces. It will be assessed that are innovative, with design and qualities that stand out. 2 points maximum. 	<p>MAX: 10</p>	

C4.-Lighting (Criterion to be evaluated by means of a value judgment must be in Document 2) See the Technical Specifications for details of aspects to be evaluated. Proposals that do not reach at least the score of 11,5 points in this criterion will be automatically excluded.		23
It will be evaluated: – <u>For the walls of the booths:</u> The high efficiency LED projectors requested will be evaluated for their degree of orientability and its integration into the project design, as well as their level of illumination and degree of temperature. 6 points maximum. – <u>For the work areas of the stands:</u> LED projectors or similar requested will be evaluated on their degree of orientability and its integration into the project design, as well as their level of illumination and temperature level. 7 points maximum. – <u>Lighting of product display shelves:</u> The lighting level and color temperature of the high efficiency and diffusion LED luminaires requested will be evaluated. 2 points maximum. – <u>Show cases lighting:</u> The LED lighting system adopted in the base, side and fronts of the glass cases, the efficiency of the lighting and the degree of temperature will be evaluated. 2 points maximum. – <u>Lighting of the identification in height:</u> Corporeal lettering, 3d backlit logos and 8T- tubes. All shall have homogeneous illumination of the same cool white color temperature (between 5,000-6,000K) and excellent grade color rendering (Ra 80-100). 6 points maximum.	MAX: 23	
Total		100

Responses C3-C4 (DOCUMENT 2) will be scored as follows:

0% of allocated points	Proposal simply states that the bidder can meet some or all the requirements but does not provide information or detail on how they will do so
25% of allocated points	Low
50% of allocated points	Compliant
75% of allocated points	Fully Compliant
100% of allocated points	Exceeds Requirements

The proposals that do not reach at least 50% of points in sections C3 and C4. will be automatically excluded.

Tiebreaker Criteria.

In the event of a tie in the score obtained by two or more bidders, it will be resolved by applying the social criteria indicated below, in order and referring to the end of the proposal submission period. The supporting documentation of the tiebreaker criteria referred to in this clause will be provided by the bidders at the time the tie occurs, and not beforehand.

- Greater percentage of workers with disabilities or in a situation of social exclusion in the workforce of each of the companies, prioritizing in case of equality, the greater number of permanent workers with disabilities in the workforce, or the greater number of workers included in workforce.
- Lower percentage of temporary contracts in the workforce of each of the companies.
- Greater percentage of women employed in the workforce of each of the companies.
- The tie if the application of the previous criteria had not given rise to a tiebreaker.

ICEX reserves the right to collect information on any incomplete aspects or questions that may arise from the bids submitted by the participating companies. Participating companies must correct the defects by the deadline indicated in each case.

Every Company taking part in the tender shall receive appropriate notice on whether ICEX has decided to award them the Contract or otherwise.

ICEX may consider that no bidders qualify for the award of the tender if following the bids and documents submitted these do not comply with minimum requirements like solvency of the Contractor, the technical project, its suitability, or the prices quoted.

ICEX reserves the right to revoke the award at any time if the winning bidder fails to fulfil any of the requirements in the Call for Bids and the General Terms and Conditions governing the tender.

The bidder with the highest score will be informed of the award as soon as possible.

THIRD. - Award sum

The price offered by the bidders shall include, among others, all expenses even those regarding fluctuations in exchange rates and cannot be modified during the period of the agreement and, if applicable, its extensions, unless express Contract thereon by the Parties.

The price tendered by the bidding company for net surface may not exceed **one hundred ninety-eight thousand Canadian dollars (198,000 CAD), 165 x 1,200 sqft**, VAT excluded.

Any quotation exceeding these amounts will be dismissed.

This is an estimated cost; if the Sqft of the Pavilion vary, it will imply a variation of the cost, according to the price per Sqft.

The price per Sqft specified in the tender, may not be varied or amended in any way by the Awardee, during the period of the Contract and following extensions unless express Contract thereon by the Parties.

The price per Sqft tendered must include all works regarding the construction, assembly, provision and connections of additional mechanisms and devices necessary to make all the equipments work, even those rented by the exhibitors such as refrigerated displays, audiovisuals, etc., maintenance and disassembly of the Spanish Pavilion, as well as all expense items arising from transport from and to the site where the Fair is held, and the necessary equipment for assembling and dismantling the Pavilion, warehousing and transport of loads within the Fair and rental of whatever other services are required within the Fair in order to execute the Agreement.

The price must also include:

- **Set up, maintenance and dismantling labours**, supervisor labours, Truckage charges, disposal costs, management fees, or the production and hanging labour (installation and dismantling) of all the hanging elements if required.
- **Disposal of Waste**. The wastes from the exhibition, used materials, and all other wastes in and around the booth shall be removed by the awardee (Construction and exhibitors wastes). The expenses for the disposal work shall be borne by the awardee. This cost will be included in the tender price.
- **Water Supply and Drainage Facilities**. All piping works shall be borne by the Awardee.
- **Cleaning** of the Pavilion during assembly, celebration and dismantling periods.
- **Civil liability insurance** that covers any claims filed following personal or property damages or losses suffered by workers, exhibitors, visitors, or any other person during, or consequently, of the assembly, dressing or dismantling of the Pavilion.

No additional extra costs will be accepted.

The price does not include:

- **Handling Charges/Drayage**.

- **Electricity and Power supply.** All electrical and pipe installations work from source of supply at the exhibition (even if these works must be carried out solely by the Organiser's official contractor). Additional connections and secondary wiring works shall be borne by the Awardee.

FOURTH. – Estimated Contract Value

The **estimated value of the contract** considers the value of the first contract, the value of two (2) possible extensions, and the possible modifications.

According to the latter, the estimated total contract value of these contracts is six hundred thirty-three thousand six hundred CAD (CAD 633,600), VAT excluded, which includes the following amounts:

- Main contract maximum budget:	CAD 198,000
- First extension maximum budget:	CAD 198,000
- Second extension maximum budget:	CAD 198,000
- Modifications (máx. 20%):	CAD 39,600

FIFTH. - Price and payment arrangement

The total price will be paid, following submission of the appropriate invoice, in the terms that ICEX and the Awardee Company agree.

ICEX will satisfy the amount specified in the tender in instalments. The first instalment of 50% will be paid upon contract signing and Contractor's presentation of the corresponding invoice.

The second instalment corresponding to the remaining 50% of the total price agreed will be paid within thirty (30) days after the conclusion of the fair upon presentation of the corresponding invoice, issued in Canadian dollars (CAD), once the penalties, if any, have been deducted.

In the event that the Tradeshow is not held, or the Pavilion is cancelled, ICEX shall solely satisfy the expenses incurred by the Contractor as from the date of award of this contract (and in connection with the same) until the date of formal notice of this circumstance by ICEX. In order to be reimbursed, the Contractor shall previously submit all documentary invoices of the expenses incurred up to that date. In the same way, the Contractor shall reimburse ICEX the amount advanced of the expenses not incurred.

Administrative requirements for billing (Invoicing details):

- All invoices must be billed to:
ICEX España Exportación e Inversiones, E.P.E.
Paseo de la Castellana 278
28046 Madrid (Spain)
- And dispatched to:
ICEX España Exportación e Inversiones, E.P.E.
Economic and Commercial Office
170 University Avenue
Floor 7th, Suite 700
Toronto (Ontario), Canada

VAT number: ESQ - 2891001F (ICEX is VAT registered in Spain)

As long as the successful bidder is a Spanish entity, it is possible that payment be made from the ICEX Spain and not from Economic and Commercial Office of Spain in Toronto.

SIXTH. - Procedure

This briefing will be circulated to multiple Companies, and will be published on the on the Economic and Commercial Office of Spain in [Toronto](#) website [link](#).

The Companies interested in bidding may contact ICEX (tenders@icex.es) with any questions about the tender before October 1st, 2024, at 10:00 AM Toronto local time.

Please note that any expenditure incurred by candidate Companies in the preparation of the proposals presentation and quotes will be at the expense of those companies involved. Submission of the offer will not generate any fees or reimbursement of any type of expenses.

Submission of an offer and participation in this tender implies the Company express acceptance of all the points contained in this briefing.

The proposal needs to be sent via email to tenders@icex.es before October 3rd, 2024, 10:00 AM Toronto local time. Otherwise, rulings of the bidding process oblige to exclude your entity from continuing in the procedure.

All files should not exceed 4mb in size if sent as attachment; should files be larger, use a file transfer service, which you have verified works.

The proposal will need to be presented in English, electronically as a pdf and where appropriate, use Excel for numbers.

All competing Companies submitting a proposal should be aware that ICEX Legal Services will review the documentation submitted to ensure that they comply with the requirements of this tender.

After verifying compliance with the Company requirements (see Document 1), the technical offer (work proposal see Document 2) will be reviewed and evaluated. Once the evaluation scores have been assigned to the technical proposal, the economic offer and automatic criteria (Document 3) will be opened and evaluated. **The price contained in the economic offer will not be known until that moment.**

A decision will be made within an estimated period of four (4) weeks from the published proposal due date. The decision will be officially notified via email, to enable the selected agency to begin work promptly.

Proposals not submitted within the deadline will be excluded.

Non-compliance with any of the requirements established in the present tender will result in the disqualification of the Company concerned.

IMPORTANT: Proposal submission must be divided into three (3) separate documents with their annexes detailed as follows:

All the documentation shall be submitted only in **ELECTRONIC FORMAT**.

- **Document 1: LEGAL DOCUMENTATION TO BE SUBMITTED**

The Tenders shall provide detailed information about their companies with reference to the following items:

- Legal status, structure, size (turnover, number of employees).
- All competing bidders will be required to provide a solvency report in order to proof that the annual volume of business, referred to the best exercise within the last three available depending on the dates of constitution or start of activities of the bidder and submission of offers, is equal to or greater than **CAD 198,000**, VAT excluded.
- Mention of other dressing projects in which they have been involved in the last three (3) years, with special skills on dressing projects for National Pavilion at Trade Fairs.

- As well as a **Letter of acceptance signed** by a legal representative of the company whereby, they accept each and every term and condition set out in this Call for a Dressing Tender and its Bidding Specifications.

- **Document 2: TECHNICAL DOCUMENTATION TO BE SUBMITTED**

The offer must necessarily include:

- Plans of the proposal, including ground plans elevations with dimensions, and overall perspectives to show a proper comprehension of the project.
- Construction details of all the main elements of the project, with sections, front views and perspectives that allow a clearly understanding of the proposed solutions.
- Project specifications, including finishes, materials and construction processes. These specifications must take into consideration the aspects indicated in the “Specifications of Works”.
- Specifications and details of the booths & overhead’s structure lighting. Specifications and technical details, including luxes and temperature of light data, design, and type of the luminaires, colour and adjustability of the spotlights. Layout with the proposed position of the luminaires in walls.
- Details and information concerning the Improvement related to the Led screen in Gastro Area.
- Specifications of the Environmental proposed project.
- Photographs or 3D model of the furniture.
- Perspectives and/or 3D computer graphics to show a proper comprehension of the project.

The formats indicated above are mandatory.

The information provide in Document 2 does not clash with the information required in Document 3. The tenderer must avoid introducing in Document 2 any reference with the prices.

➤ Only this information prepared by the bidders included in Document 2 will be used to evaluate the criteria set forth in this tender.

- **Document 3: ECONOMICAL PROPOSAL & CRITERIA C.2. ENVIROMENTAL**

Documentation to be submitted by the bidders:

ECONOMICAL PROPOSAL

Economic proposal must be in CAD.

- Breakdown of the total cost in estimated percentage:
 - Previous works-Production (booths, electricals, water, etc): %
 - Site works (set up and dismantling): %
 - Transportation, load and unload service: %
 - Management and operation services fees: %
- Detailed budget by chapter and by item, stating the unit prices.

ICEX will evaluate tenders based on the offered prices, excluding VAT.

The tenders should include a breakdown in which the price offered, and taxes are clearly separated.

Proposals exceeding the maximum available budget **CAD 198,000 (CAD 165 x 1,200 sqft)**, VAT excluded, will not be considered.

AUTOMATIC CRITERIA: C.2. Environmental Criteria

Annex 6 Economical Offer & Environmental criteria duly fulfilled.

SEVENTH. -Entering into an Agreement

The legal relationship between the successful Awardee of the tender and ICEX shall be recorded following the execution of a Contract. Prior the signing of this Contract, the Awardee must submit within the terms established for the same, the documentation foreseen in the Schedule of these Bidding Specifications (**Annex 1** and **Annex 2** only for the awardee).

EIGHTH. – Procurement Board

Appointed members of the Procurement Board for purposes of this tender will be:

President	Pablo Conde Díez del Corral	General Director of Internationalization.
Substitute	María Naranjo Crespo	Food Industry Director.
Member	Salomé Martínez Aparicio	Food Industry Assistant Director.
Substitute	Alberto Blanco Vicente	Area Manager, Architecture Department.
Member	Pilar Randolph Riera	Director Food & Wines from Spain. Trade Commission of Spain in Toronto.
Substitute	Lidia Escribano García	Head of Food & Beverages Department.
Member	Cristina Saura Fischer	Area Manager, Food & Beverages Department.
Substitute	Lidia Martínez Gracia	Area Manager, Food & Beverages Department.
Secretary	Pedro Patiño Segura	Head of Procurement Department.
Substitute	M ^a Elena Menéndez Fombona	Member of the Procurement Department.

NINETH. - Extension of the contract

In order to uphold the institutional image of Spain at International Trade Shows or Fairs, ICEX hereby reserves the right to extend the contract signed with the Awardee for a maximum of the following two (2) editions of the Trade Fair regardless the date of execution without convening a new tender. The general terms and conditions of the Bidding Specifications governing this Tender shall apply to the extension.

TENTH. – Modification of the contract

Once the contract has been formalized, the modifications considered necessary for its correct execution may be agreed, as long as they do not alter the global nature of the initial contract or imply a substantial modification. For these purposes, those whose cost implies a variation in the contract price of more than 20% will be considered a substantial modification.

Possible changes in the contract price may be due to a change in the fair location or to new functionalities in the program of needs and / or equipment of the institutional stand or company stands, the inclusion of elements that reinforce the signage at height, which it may be necessary to introduce in this or the next two (2) editions of this fair if the contract is extended.

In this case, the successful tenderer will provide in writing, at the request of ICEX, the technical, economic and other conditions, before carrying out any modification to the contract. The modification must be previously approved by ICEX and formalized in the corresponding contract.

ELEVENTH. - Force Majeure or restrictions imposed by the Fair Ground Authorities

The successful Awardee of the tender and ICEX will not be responsible for the damages and losses caused to the other party for delays or breaches of the contract that bring their cause in cases of *force majeure* or restrictions imposed by the Fair Ground Authorities. The duties of this contract will be considered suspended while the situation of *force majeure* or trade fair restriction lasts, and the parties will try to reach an agreement in good faith that benefits their respective interests as much as possible. In any case, the party that has knowledge of these facts must inform the other as soon as possible so that said duties are suspended or that the measures deemed appropriate are adopted. If the cause of *Force Majeure* or trade fair restriction extends in time until 2025, either party will be entitled to request the termination of the contract without having to indemnify the other party for it.

TWELFTH. - Cancellation or postponement of the fair

In the event that the Tradeshow is not held in 2025 or 2026, or the Pavilion is cancelled in 2025 and 2026, ICEX shall solely satisfy the expenses incurred by the Contractor as from the date of award of this contract (and in connection with the same) until the date of formal notice of this circumstance by ICEX. In order to be reimbursed, the Contractor shall previously submit all documentary invoices of the expenses incurred up to that date. In the same way, the Contractor shall reimburse ICEX the amount advanced of the expenses not incurred.

THIRTEENTH. -Execution of the contract

ICEX Project Manager is ultimately responsible for setting up the Pavilion. In the absence thereof, the Coordinator or Manager of the Spanish Pavilion will have ultimate responsibility. Any specific requests made by the exhibiting companies shall be responded to after consulting Project Management. The successful bidder shall not, under any circumstances, respond directly to oral requests, which must be addressed to: toronto@comercio.mineco.es

All construction, assembly and dressing work, in connection with the Pavilion, must be completed twelve (12) hours before the Trade Fair Opening at latest except in the event of force majeure or restrictions imposed by the Fairground Authorities. The last day of such works shall be devoted to cleaning tasks in general and attention to stands. The Pavilion must be completely clean one (1) hour before the Trade Fair opening.

All works must be conducted pursuant to the technical specifications set out in these bidding specifications (Section B – Technical Specifications) and with adequate materials/furniture and finish, whereby faulty or low-quality materials shall not be acceptable.

The Awardee is likewise obliged to dismantle the stands within the term and provisions contemplated in the Regulations of the Enclosure, as well to the instructions given by ICEX or its representatives at the Trade Fair.

FOURTEENTH. - Obligations of the Contractor

The Contractor shall be responsible for compliance of all technical regulations established by the Trade Fair Regulations, and to submit them layouts needed for approval as well as for the payment of the deposits asked by Organisers to allow the works at Exhibition Hall that have to be included in the Tender price.

The Contractor shall avail itself of the necessary human and technical resources in order to meet its obligations. In the event that the Contractor subcontracts any of the works herein assigned to the latter, only the Contractor shall be held liable to ICEX, without recourse to the subcontracting company.

Likewise, the provisioning of services and obtaining the necessary permits and authorisations and insurance required to undertake the assembly, dressing and dismantling works concerning the Pavilion shall be fully met by the Contractor. In any event, the Awardee must take out a civil

liability insurance which covers any claims filed following personal or property damages or losses suffered by workers, exhibitors, visitors or any other person during, or as a consequence, of the assembly, dressing or dismantling of the Pavilion. All costs arising from these items must be included in tenderer's price offer submitted.

The Contractor hereby undertakes that throughout the assembly process of the Pavilion, it shall appoint a person vested with sufficient capacity to order the changes which may be required following unforeseen or uncomfortable circumstances during the assembly process.

The Contractor shall likewise provide ICEX with the number of workers required in order to help the exhibitors during the afternoon previous to the Trade Fair inauguration and the morning in which the Trade Fair has been inaugurated and at least two (2) members of its "in-house" personnel to ensure "on-site" proper maintenance of the Pavilion throughout the Tradeshow.

ICEX is entitled to amend or cancel specific items and in that event the Contractor shall be notified of the foregoing sufficiently in advance.

FIFTEENTH. – Subcontracting

The contractor will not be allowed to subcontract any of the works assigned hereof, unless ICEX previous authorization. In that event, exclusively the contractor will be held liable before ICEX for the works or omissions of the subcontracted company.

SIXTEENTH. - Ownership of the designs

All designs used in the Spanish Pavilion are the proprietary ownership of the ICEX, and may not be reproduced, copied or used by the Contractor for any other clients or projects.

SEVENTEENTH. - Health and Safety at Work

The Awardee shall be responsible for compliance of all industrial, health and safety regulations established by the legislation of the country in which the Trade Fair is held and by the Regulations of the Enclosure.

EIGHTEENTH. – Penalties

18.1 Assembly

ICEX may impose penalties following an inadequate or poor finish, the use of faulty or badly preserved materials, and in general, for any assembly deficiencies. Such penalties shall be reckoned pro rata to the damages caused.

Any delivery delay on the agreed schedule (12 hours before each one of the Trade fair Openings) shall entail a 4% penalty on the total amount of the Contract for each of the first three (3) hours or fraction of an hour, with an additional 10% surcharge from the fourth to the sixth hour. Should the delay exceed six (6) hours, ICEX shall study the appropriate penalty thereon, which in no event shall be more than the result of applying 50% to the total consideration of the Agreement.

In the event that the works are not completed when the opening of the Fair takes place, ICEX may, notwithstanding the penalties foreseen in the foregoing paragraph, claim damages from the Contractor (likewise referred to as the Awardee).

When delay in completion of works is due to any breach of the Trade Fair Regulations, the penalty system abovementioned shall be enforced.

If all the required elements of the stands are not made available to the participants in due time and manner, ICEX is entitled to apply the penalties it deems appropriate, and ICEX reserves the right to lease such elements to third parties.

18.2 Pavilion maintenance and deficiencies during the fair

ICEX may impose penalties if the execution of the Pavilion maintenance work during the duration of the fair is not carried out properly and within a reasonable period of time to guarantee the normal functioning of the Pavilion; The amount will be set in proportion to the damages caused by the delay and/or poor execution of the work, after hearing the contractor and by agreement of the contracting authority.

Likewise, ICEX may establish penalties for damages caused during the days of the fair resulting from the use of inappropriate materials, materials not approved by the fair regulations, due to defects in the installation of constituent parts of the stand, which will also be assessed the implications for ICEX or third parties may arise from omissions, errors, inadequate methods or incorrect conclusions in the execution of the contract. The successful bidder must carry out the correction of defective or incorrect work at his own expense. Penalties will be calculated in proportion to the damages caused, after hearing the contractor and by agreement of the contracting body.

The higher penalties for these concepts will be the following:

- Due to deficiencies in maintenance work during the days of the fair, it may be up to 10% of the contract price.
- Deficiencies in the pavilion, as set out above, that appear during the days of the fair, up to 10% of the contract price.

18.3 Dismantling

ICEX may establish penalties in the event of an inadequate dismantling and withdrawal of the elements used in connection with the decoration of the Pavilion, pursuant to the Fair Grounds Regulations thereon pro rata to the damages caused.

Breach of the dismantling schedule as set out in the Fair Grounds Regulations shall entail the application of a penalty.

Any dismantling delay on the agreed schedule by the Fair Ground Regulations shall entail a 4% penalty on the total amount of the Agreement for each of the first sixth hour. Should the delay exceed six (6) hours, ICEX shall study the appropriate penalty thereon, which in no event shall be less than 10% of the aggregate consideration for the Contract.

18.4 Non-celebration of the fair

In the event of the Fair is not held, or the Pavilion is cancelled, ICEX will only cover the expenses incurred by the Contractor from the date of communication of the start of the work (and in relation to it) until the date of formal notification of this circumstance by ICEX. To be reimbursed, the Contractor must previously present all invoices or other documentation of expenses incurred up to that date.

NINETEENTH. – Termination

ICEX is entitled to terminate the Contract following a breach of the Contractor of any of its contractual obligations, in addition to any claim for damages and legal remedies which may be available.

TWENTIETH. - Applicable legislation

Dressing works shall be governed by the terms of the contract entered into between the awardee Contractor Company and by the tender specifications, which shall be incorporated to the same, and in default of the above, the Spanish legislation shall be applicable.

TWENTY-FIRST. – Jurisdiction

In order to solve any dispute, disagreement, issue or claim which may arise from the performance or construction of the Contract executed with the successful Awardee of this tender, the matter will be referred to the ordinary Courts. The parties, renouncing the jurisdiction that may correspond, expressly submit to the Courts of the city of Madrid.

SECTION B – TECHNICAL SPECIFICATIONS

SPECIFICATIONS OF WORKS

Trade Fair	Date	Venue	Estimated surface
SIAL CANADA 2025	April 29 - May 1, 2025	Energcare Centre, Toronto, Canada	1,200 sqft / 111.48 sqm

The bidder must submit a proposal fitted to the design provided and, if necessary, include slight changes in order to improve the image of Spain as a country that produces high quality and design.

Therefore, it must contain items and materials that the bidder deems appropriate for this purpose.

The Awardee shall be responsible for compliance of all technical regulations established by the Trade Fair Regulations, and to submit them layouts needed for approval as well as for the payment of the deposits asked by Organizers to allow the works at Exhibition Hall that have to be included in the Tender price.

All materials used in the stand construction must be properly fireproofed in accordance with local regulations.

The plans attached are only indicative. A final layout will be sent, if necessary, to the awardee in good time before the dates of the Show. The modifications will be made by the contractor at no extra cost.

The tender must include in the technical documentation:

- Plans of the proposal, including ground plans elevations with dimensions, and overall perspectives to show a proper comprehension of the project.
- Construction details of all the main elements of the project, with sections, front views and perspectives that allow a clearly understanding of the proposed solutions.
- Project specifications, including finishes, materials and construction processes. These specifications must take into consideration the aspects indicated in the “Specifications of Works”.
- Specifications and details of the booths & overhead’s structure lighting. Specifications and technical details, including luxes and temperature of light data, design, and type of the luminaires, colour and adjustability of the spotlights. Layout with the proposed position of the luminaires in walls.
- Details and information concerning the Improvement related to the Led screen in Gastro Area.
- Specifications of the Environmental proposed project.
- Photographs or 3D model of the furniture.
- Perspectives and/or 3D computer graphics to show a proper comprehension of the project.

Furthermore, the decorator undertakes to pay any fee arising from performance of work outside hours at the venue, and any other fee that the venue organization might request, both at the beginning and at the end of the show, which are not included in these specifications.

The bidder must consider in its quotation the following works:

The structure of the pavilion should undertake an open space scheme with the following requirements:

1. FLOORING
2. REAR WALLS
 - 2.1. PERSONALISED GRAPHICS FOR EACH BOOTH
 - 2.2. SIGNAGE AND IDENTIFICATION OF BOOTHS.
 - 2.3. STOREROOMS
 - 2.4. INSTALLATION OF SHELVES FOR EXHIBITION
3. DIVIDING WALLS BETWEEN BOOTHS
4. BASIC EXHIBITION FURNITURE INCLUDED IN THE OFFER
5. LIGHTING
 - 5.1. LIGHTING OF THE WALLS AND WORK AREA OF THE BOOTHS
 - 5.2. LIGHTING PRODUCT DISPLAY SHELVES
 - 5.3. ILLUMINATION OF SHOWCASES
 - 5.4. ILLUMINATION OF THE IDENTIFICATION IN HEIGHT
6. OVERHEAD'S SIGNAGE
 - 6.1. DESCRIPTION
 - 6.2. MEASUREMENTS
 - 6.3. MATERIALS
 - 6.4. HEADWALLS
 - 6.5. INSIDE THE BOX: CORPOREAL LETTERS (3D) AND T8 LED TUBES
 - 6.5.1. Backplane: T8 LED tubes and claims
 - 6.5.2. Front plane: corporeal text and logos (3D)
7. INSTITUTIONAL SING HUNG
8. INSTITUTIONAL AREAS. Icx's booth/ Show cooking area
 - 8.1. ICEX INFORMATION BOOTH
 - 8.2. SHOW COOKING AREA
 - 8.2.1. Flooring
 - 8.2.2. Storage & preparation room
 - 8.2.3. Open area
 - 8.2.4. Graphics
 - 8.2.5. Cleaning
9. INSTITUTIONAL SIGNAGE. ICEX CORPORATE IMAGE
10. ELECTRICITY AND LIGHTING
11. PLUMBING
12. CLEANING OF THE PAVILION AND COLLECTION OF DISPOSABLE MATERIALS
13. FEES FOR ADVANCE SET-UP OR RENTAL OF SPACE FOR OUT-OF-HOURS WORK INSIDE THE FAIRGROUNDS
14. FIRE REGULATIONS
15. SANITARY REGULATIONS
16. OTHERS

DESIGN AND CONSTRUCTION

The design of the Spain Pavilion, which is presented together with this tender as **Annex 3**, aims to add value to the presence and image of Spain, as well as to serve as a platform for the pavilion's exhibitors to personalize their participation in each fair.

The main basis of the project is based on the differentiation of three levels of communication:

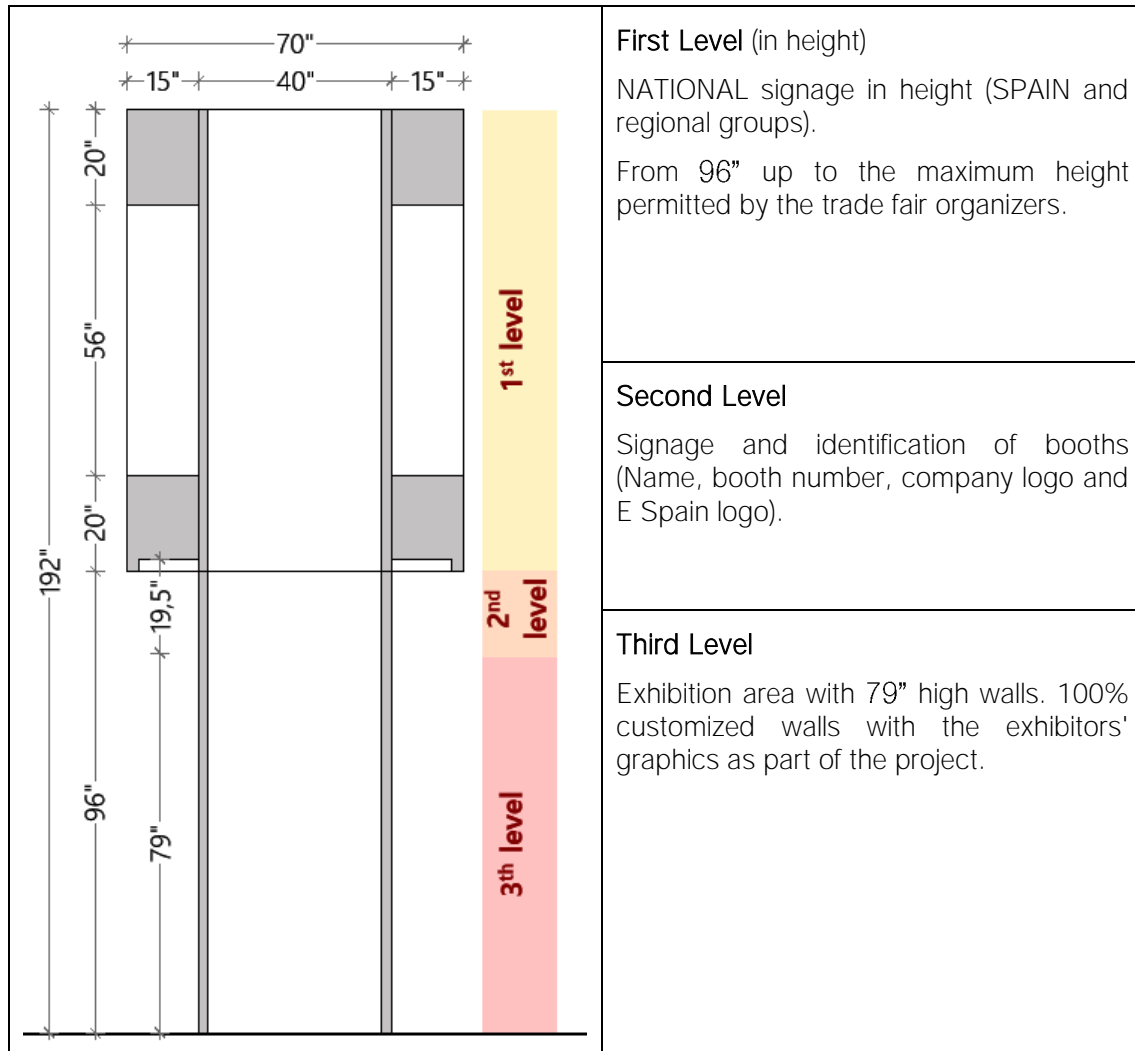

1 FLOORING

The floor of EXHIBITOR'S BOOTHS will be covered with carpet on foam padding. The color of the carpet will be black.

All wires, pipes or any other installation items have to be concealed under the carpet, inside the foam padding.

In order to protect the floor materials, visqueen or similar cover will have to be installed over them prior to installation of the exhibits. Works to remove the cover before the inauguration must be included in the overall price, as well as works to remove all floorings after the show closes and all relevant work costs related to the floorings.

Carpet has to be thick, (American standard) not European standard.

Aspects to be assessed in the criteria table:

MATERIALS AND CONSTRUCTION SYSTEMS:

STRUCTURES AT HEIGHT, FLOORS AND WALLS

- Types of materials and composition.
- Mechanization and assembly of the pieces that make up the floor to minimize assembly times.

2 REAR WALLS

The rear walls shall be the axis that configures the contracted spaces for the pavilion. They shall be raised to a maximum height of 8' above ground level (including the thickness of the stand floor), and shall delimit the storage areas, the depth of which shall be 40".

The side walls shall be set back 4" from the edge of the platform and will be covered with institutional graphics.

The resulting structure shall comply with the following objectives:

- Principle of stability.
- Capacity to accommodate maximum storage for exhibitors' goods.
- Ability to conceal the electrical panels and lighting equipment inside (space shall be provided to conceal the electrical panels at the ends of the islands). In any case, electrical switchboards may not be placed in the storage spaces allocated to the booths.
- Continuous look construction without interruptions. Concealed internal structure.

Aspects to be assessed in the criteria table:

MATERIALS AND CONSTRUCTION SYSTEMS:

STRUCTURES AT HEIGHT, FLOORS AND WALLS

- Types of materials and composition.
- Mechanization and assembly of the pieces that make up the rear walls to minimize assembly times.

The back walls will serve as a support for the personalized graphics. The parts not covered by graphics will have a matt white finish.

2.1 PERSONALISED GRAPHICS FOR EACH BOOTH.

The focus of the project is the custom designed graphics that each booth will have to cover the entire dimension of its back wall (in height-79" x the individual length of each booth), as part of the project design, included in the tender price.

The tender will include the production and installation of the graphic material, which will be made on the back walls of the booths on high quality adhesive vinyl or canvas. Rigid or semi-flexible supports will not be accepted for the graphics. The graphics shall cover the entire wall, in height and length, including the door panel of the warehouse, which shall not have visible opening knobs to avoid protrusions in the view of the graphics. The graphics shall be neatly stretched and the visible edges, including those of the storeroom door, shall be straight and neatly trimmed.

The shelves of each booth shall be placed on the wall once the graphic has been placed on it.

The company awarded the contract shall be responsible for attending to, supervising and coordinating the reception of the final artwork of the graphics that each exhibitor shall send them for subsequent production and installation, tasks that shall be carried out by the company awarded the contract and which are included in the bid.

2.2 SIGNAGE AND IDENTIFICATION OF BOOTHS.

It shall occupy the upper part of the wall on a continuous strip of approximately 20" height, and shall include the following identifying elements:

- Exhibitor company lettering.
- Label of the regional groups (if applicable).
- Booth number.
- Company logo on cut vinyl.
- E Spain Logo

The letterings and booth numbers will be black (Label of the regional groups will be in the color indicated by ICEX), in capital letters, Helvetica Neue font.

The awardee company will be responsible of coordinating and recollected the artworks from the exhibitors and layout the booth ID based on the instructions given by ICEX.

Aspects to be assessed in the criteria table:

MATERIALS AND CONSTRUCTION SYSTEMS:

GRAPHICS ON WALLS.

- Type of material and composition.
- Placement system.
- Printing system.

2.3 STOREROOMS

The doors of the storerooms will have the same finish as the rest of the wall and will also serve as a base for the personalization of booths with graphic images, so they will not have visible knobs. The interior will be equipped with shelves (4 levels) on which standing bottles can be placed (15" free height between shelves) and with wall hangers for coats.

The storeroom door will have a lock. At least 2 copies of the key will be provided to exhibitors.

The awardee company will manage the delivery of keys to the exhibitors.

2.4 INSTALLATION OF SHELVES FOR EXHIBITION

These pieces of furniture will be weight resistant, made in a very good and aesthetic material and finishing. Shelves will be anchored to the wall with **hidden fixings**, and each one of them will be illuminated with a system of LED lamps.

They shall be approximately 40" long* 10"-15" deep. The finish may be proposed by the bidder, provided that it complies with the technical specifications required in these specifications (laminated-wood in white, transparent methacrylate, metallic finishes, etc.).

The net height of separation between shelves shall be 15" uniformly for all booths.

Shelf's load: It is essential to bear in mind that the products exhibited at agri-food sector fairs are samples with considerable weights (bottles, jars and tins of preserves, etc.) which can endanger the stability of the shelves. It is estimated that the racks will support an average load of 25kgs. For this reason, it will be required that the shelves are fixed with metal pins that go through the thickness of the wall and that have a reinforcement on the inside face of the wall.

Aspects to be assessed in the criteria table:

MATERIALS AND CONSTRUCTION SYSTEMS:

FURNITURE / Shelves and display cases.

- Shelves

3 DIVIDING WALLS BETWEEN BOOTHS

The separation between booths will be made with partitions whose height will be 48” and length 78”. Its supporting base shall be made up of a sufficiently solid and resistant base to hold the translucent piece, and the bid must propose an installation system that ensures the complete stability of the piece.

The color of the base shall be the same as the platform: **black**. The height and width of the base shall be kept to the minimum possible.

The material of the partition (excluding the base) will be 100% transparent to maintain a full view of the booths along the aisles, although a translucent acid-etched vinyl will be integrated in a circular shape (34” in diameter) to give partial privacy between booths.

These walls will be free of signage and any other element that may obscure the total view of the rest of the booths in a row.

Aspects to be assessed in the criteria table:

MATERIALS AND CONSTRUCTION SYSTEMS:

SEPARATIONS BETWEEN BOOTHS

- Type of material and composition.
- Installation system.
- Level of stability.

4 BASIC EXHIBITION FURNITURE INCLUDED IN THE OFFER

One set of furniture is established for every 100 square feet.

Booth dimension	Showcase counter	Shelves (40”*10-15”)	White table 30” Ø	White Chairs
100 sqft	1	3	1	4

In addition to the above-mentioned items, the basic equipment of the booths will also include:

- 1 small waste bin, with set of rubbish bags/per table for all exhibitors.
- 1 double 500-Watt power socket for every 100 sqft. of booth space, to connect chargers, laptops, etc. installed inside the counter display.
- Shelves (4 levels) inside the storage.
- Wall hangers inside the storage.
- Installation of power socket for cooling and cooking equipment. Power supply is not including in the offer, but installation of the socket must be assumed by the awardee company when it is required.

Showcase counter.

A simple, elegant, easy-to-use design that allows the exhibitors' products to be displayed will be valued.

The counter must satisfy the following technical characteristics:

- Made of high-quality black board, with concealed fittings and screws.
- Dimensions: 39”-47” length * 19”-23,5” depth * 39”-41” height.
- The lower part of the counter will have a full space to store, inner shelf and lockable doors. At least 2 copies of the key will be provided to exhibitors.
- a double 500-Watt power socket will be installed inside the counter.
- The furniture will have an illuminated display case made of security glass, where exhibitors can place their products. This display case must be lockable.

- The company logo will be included on the front of all exhibition counters. This logo will always be in a monochrome version with cut vinyl.
- When it is required, a supplementary wedge shall be provided for the interior of the showcase to place the product on an inclined or flat angle:

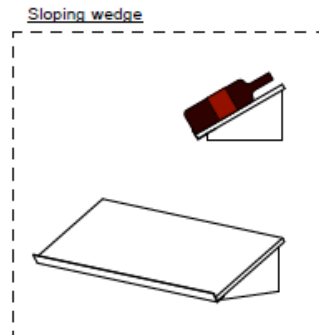

Tables and chairs

Tables shall preferably be white circular (30" diameter approx.), avoiding glass or transparent tops.

Chairs should be white, comfortable, ergonomic and stackable. Preferably of Spanish design.

Aspects to be assessed in the criteria table:

MATERIALS AND CONSTRUCTION SYSTEMS:

FURNITURE/ Shelves and show cases.

- Showcase
- Furniture

5 LIGHTING

We want to emphasize the importance of this section within the decoration tender.

5.1 LIGHTING OF THE WALLS AND WORK AREA OF THE BOOTHS

The lighting projects presented must satisfy the following technical characteristics:

- The lighting will use LED technology.
- All lights must have the same cool white color temperature (between 5,000-6,000K) and excellent color rendering (Ra 80-100).
- The spotlights and luminaires used will be perfectly integrated into the decoration project (from an aesthetic point of view).
- The lighting will be homogeneous, it will not cause uncomfortable shadows or glare.
- For the work area of the booths, light intensity will be at least 600 lux, Considering a 200 lux of environment lighting.
- The lighting on the upper shelf will be at least 1000 lux. Considering a 200 lux of environment lighting.
- Lighting must achieve at least 1000 lux of illumination over the full height and length of the booth walls. This minimum light output shall be considered for the lower part of the wall considering it to be white or light colored. The light output shall not be less than 450 lux in situations where the wall or graphic is black or dark in color. All lights must have the same cool white color temperature (between 5,000-6,000K) and excellent color rendering (Ra 80-100). They will be considered 200 lux of environment lighting.

Information must be provided on the technical characteristics of the luminaires, as well as their distribution in the project.

5.2 LIGHTING PRODUCT DISPLAY SHELVES

All shelf levels will have their own zenithal lighting, except for the upper shelves. The lighting will use LED technology. The lamps shall be of high efficiency and diffusion and shall perfectly illuminate the products displayed on each shelf.

At least 1000 lux of illumination must be achieved for the products displayed on the 2 lower shelves. All lights shall have the same cool white color temperature (between 5,000-6,000K) and excellent color rendering (Ra 80-100).

The tender shall take into account that the electrical wiring of the shelf lighting must be concealed, as well as the fixing system for the shelves. The construction solution shall be detailed, both in the descriptive report and in drawings. Construction details shall be provided with sections and perspectives in which the lighting system is visually explained.

5.3 ILLUMINATION OF SHOWCASES

They shall have a LED lighting system. Lamps with high brightness ranges and light diffusion to perfectly illuminate the products displayed.

At least 1000 lux of illumination shall be achieved inside the display case. All lights shall have the same cool white color temperature (between 5,000-6,000K) and excellent color rendering (Ra 80-100).

5.4 ILLUMINATION OF THE IDENTIFICATION IN HEIGHT.

All illuminated 3D-lettering shall have homogeneous illumination of the same cool white color temperature (between 5,000-6,000K) and excellent color rendering (Ra 80-100).

Aspects to be assessed in the criteria table:

LIGHTING

- Lighting system for the walls of the booths.
- Lighting system for the work areas of the booths.
- Lighting system for sample display shelves.
- Lighting system for show cases.
- Lighting system for the identification in height

6 OVERHEAD'S SIGNAGE

6.1 DESCRIPTION:

The Spain pavilions will be identified at height, above the stand level, by means of large horizontal prismatic volumes that will crown all the spaces destined for the National Pavilion.

These volumes are defined as large boxes open on two sides (the main sides opening onto the exhibition aisle).

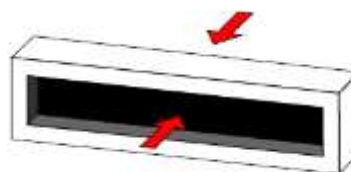

In order to ensure stability, resistance and structural support of the piece, each volume shall be built with an internal reinforcement, which shall divide the prism longitudinally in half, by means of a black panel.

The inner part of the box shall be black, and the outer part may be PANTONE RED 485C or PANTONE YELLOW 116C.

Up to this point, we have roughly defined the structure of a theatre stage, which will allow us to present our story to the visitors of the fair, and for this it is time to define both the stage and the message of the country that we want to communicate.

Inside the box, we will place, on both sides, lighted corporeal letters (3D) of different typographies and sizes, as well as LED tubes that will provide movement, depth and lighting inside the box.

6.2 MEASUREMENTS

The prism that will define the scenography space in height will could be between 68"-78" deep, its length will vary according to the island or peninsula, and its height will be 96" approx.

The lower part will have a 3" approx. recess to hide the spotlights used to illuminate the booths.

The height of the signage will be 96" above the level of the exhibition floor and must always be adjusted to the maximum height permitted by the exhibition organizers.

6.3 MATERIALS.

The finish must give a sense of continuity. The structure used may be aluminum profiles, wooden frames, or any other structure provided that it is completely hidden.

6.4 HEADWALLS

On all the sides of the boxes, the word:

ES
PA
ÑA

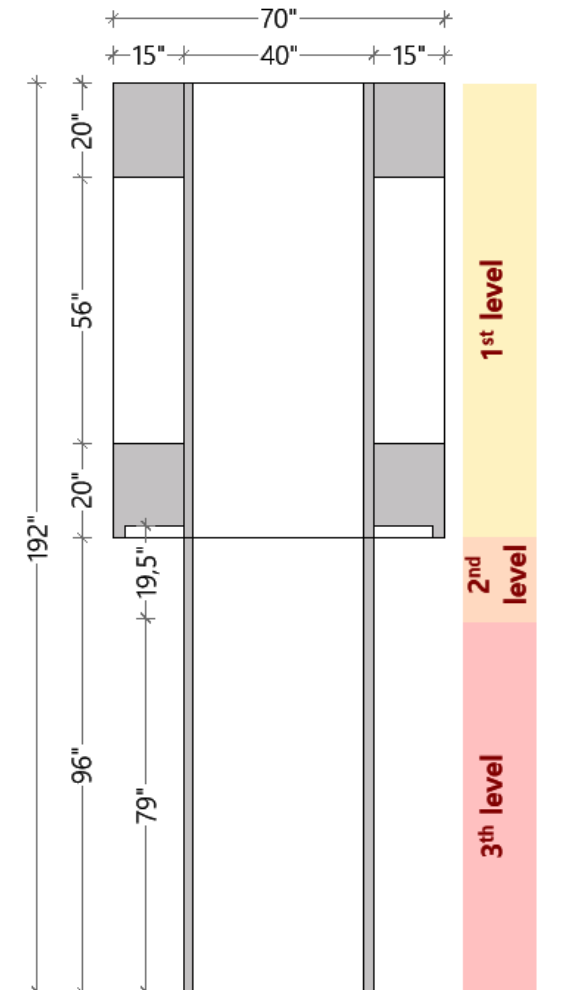

Centered on the piece, in capital letters and Bliss Light typography (Annex 5). Height of the lettering 18". The letters will be backlit with bright light.

The headwalls will extend 4" from the storeroom wall:

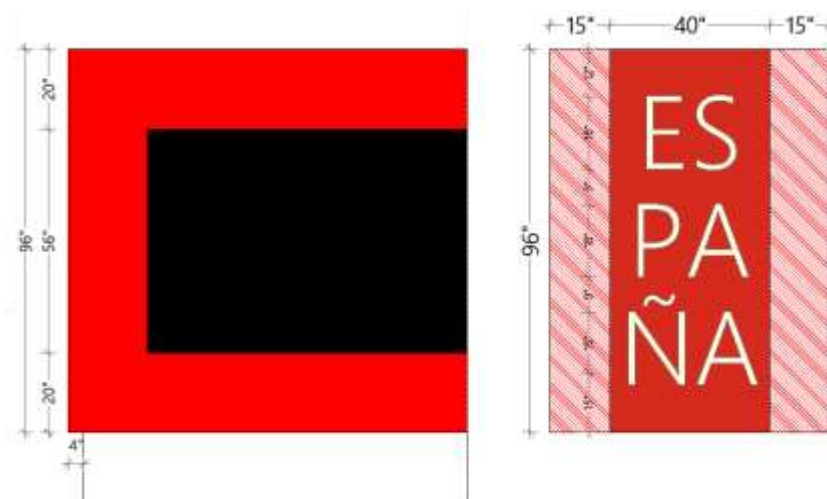

6.5 TINSIDE THE BOX: CORPOREAL LETTERS (3D) AND T8 LED TUBES

The interior of the box is made up of 2 planes: back plane and front plane.

6.5.1 Backplane: T8 LED tubes and claims:

The rear plane is made up of a series of panels that include 2' and 4' long T8 LED tubes, 24W or similar and 3D text (claims, see **Annex 4 & 5**):

Texts, sizes and fonts will be as follows:

- Tasting Spain. Typography: Circular Std Black Occidental. Font size 12".
- Spain in your Plate. Typography: Circular Std Black Occidental. Font size 12".

For details on the placement of T8 LED tubes and backlit claims, see **Annex 3**.

The lighting should be very bright and intense. All lights shall have the same cold white color temperature (between 5,000-6,000K) and excellent color rendering (Ra 80-100).

The successful bidder must propose a system so that the wiring and the tube fastenings are not visible.

6.5.2 Front plane: corporeal text and logos (3D):

In the front plan, inside the boxes there will be a series of backlit texts and logos, which will be corporeal. The letters will be placed on both sides of the box. See **Annex 3**.



Texts, sizes and fonts will be as follows:

- Spain/ España. Typography: HelveticaNeueLT Pro-75 Bd. Font size 38". See **Annex 4 & 5**
- Spain Logo "Virgulilla". It will be 165" long (for 40' long islands the "Virgulilla" will be 120" long). (Pantone colors Red 485C; Yellow 116C). See **Annex 4**.
- Regional logo. Maximum size 165" long and 45" high. Icx will send the text and instructions well in advance. It is estimated that at least the following Regional Groups may be present: Galicia, Región de Murcia, Comunitat Valenciana and Castilla y León. See **Annex 4**.

All the 3d letters and logos, must be backlit as in the following scheme:



The lighting should be very bright and intense. All lights shall have the same cold white color temperature (between 5,000-6,000K) and excellent color rendering (Ra 80-100).

The successful bidder must propose a system for placing the lettering in the "scenography space", concealing the wiring and ensuring that the fastening elements are completely unnoticed and avoid concealing other lettering or lighting elements.

For details on the placement of 3d backlit text and logos, see **Annex 3**.

Aspects to be assessed in the criteria table:

MATERIALS AND CONSTRUCTION SYSTEMS:

STRUCTURES AT HEIGHT, FLOORS AND WALLS

- Types of materials and composition.
- Mechanization and assembly
- Type of material and composition destined to the identification of Spain / España...

7 INSTITUTIONAL SING HUNG

The objective of this signage is to highlight the location of the Pavilion of SPAIN along the main aisles of the Show.

We propose a circular overhead double printed structure of at maximum 20' Ø x 3' (H).

Both sides will show the same red background (red Pantone 485C) and the word Spain in typography HelveticaNeueLT Pro-75 Bd (See **Annex 4 & 5**):



The contractor will be in charge of (and will be held responsible for) the hanging service fittings and ordering of the Official supplier. All hanging costs must be included in the Tender (load calculations, trusses, suspension systems...).

8 INSTITUTIONAL AREAS. Icx's booth/ Show cooking area

8.1 ICEX INFORMATION BOOTH

All ICEX information booths will have at least:

- 1 black ICEX information counter of simple design with interior storage for promotional material and leaflets with key and interior shelves [approx. 80" (L) x 20" (W) x 40"(H)]. ICEX logo cutting vinyl in a monochrome white version will be included on the front of the counter. No aluminum modular system will be accepted. Must include a 500W double power socket inside. See **Annex 3**.

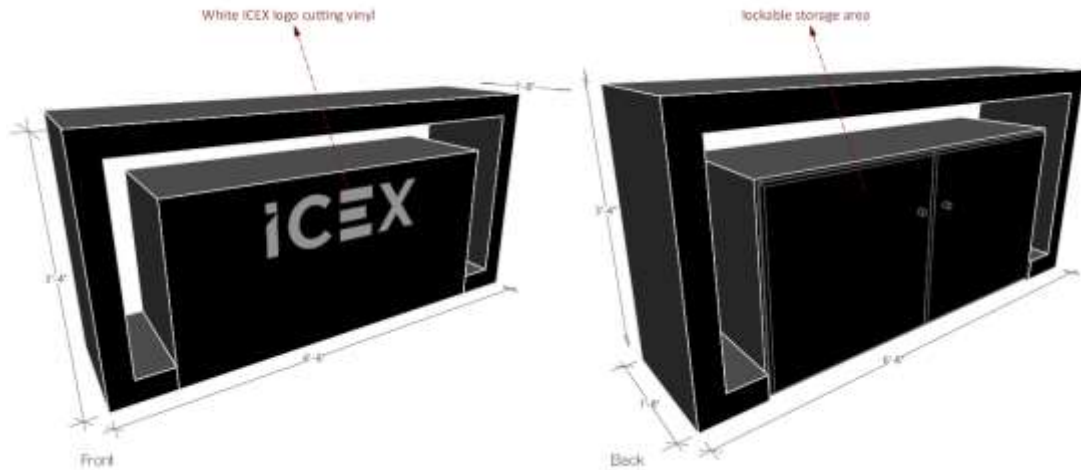

- 1 high white bar table 24" Ø (*when it is required*)
- 4 high white chairs (*when it is required*)
- Four white chairs
- 1 round white table 30" Ø
- A waste bin.
- Full walls graphics.
- A laptop, and Wi-Fi and connection for the computer equipment (*when it is required*).
- Relaxed meeting space with low armchairs, low table and floor lamp. 1 double 500 W power socket (when it is required).
- LED screen, 70"-80" with HDMI and USB input, (*when it is required*). ICEX will provide the contractor with the videos to be mounted on a carousel.

A storage room to accommodate:

- Small fridge A+ in energy consumption and 24hrs power socket.
- Coffee machine with capsules (50 per day), milk (50 individual capsules/day) and teaspoons (50 per day).
- Water fountain with jerry can refill (2 refills per day).
- Shelving with 5 shelves
- 500 W power sockets required.
- Wall-mounted coat and bag racks.
- Locker cabinet or similar
- Cleaning set with paper towels and cleaning liquids.

8.2 SHOW COOKING AREA:

For the 2025 edition, any show cooking area is planned. If the space were increased in following editions (2026 or 2027), a space of 600-800 sqft could be foreseen for this purpose. In that case it should have the following characteristics:

8.2.1 Flooring:

The floor of EXHIBITOR'S BOOTHS will be covered with carpet on foam padding. The color of the carpet will be black.

All wires, pipes or any other installation items must be concealed under the carpet, inside the foam padding.

To protect the floor materials, visqueen or similar cover will have to be installed over them prior to installation of the exhibits. Works to remove the cover before the inauguration must be included in the overall price.

Carpet must be thick, (American standard) not European standard.

8.2.2 Storage & preparation room with lockable door provide with:

- 6 Reinforced shelves.
- 2 wall Clothes racks.
- 2 lockable cupboards.
- 2 large trash cans
- Plumbing. Double Sink/water connection/drainage
- One perimeter working countertop.
- Electrical connections for all the devices.
- Electrical devices:
 - 1 king size Fridge/Freezer
 - 1 Microwave oven.
 - 1 Industrial wash Disher.
 - 1 Electrical oven.
 - 5 portable Induction Cooktops
 - 1 Extractor hood
 - 1 electrical water heater

8.2.3 Open area:

Low walls on lateral aisles to protect the area from general public on aisles. Translucent material with institutional logos and graphics decorating (vinyl stickers).

- 1 video led screen 120" x 60" approx.
- 1 Headset Microphone & speakers set.
- 1 table for the speaker and for the show cooking. H 37"x L120" x W32" approx. Front closed and fully covered by graphic, interior shelving. With electrical connections for the show cooking devices (speakers, portable Induction Cooktops, etc.).
- Electrical connections for all the devices.
- 1 Camera to record the show cooking to watch on the video led screen.
- Longitudinal 40" (H) tables. (see approximate measurements in **Annex 3**)
- 25-30 high white chairs for the seminar's attendees.
- Tablecloths for all the mentioned tables.
- 2 Spittoons.

The bidder assumes the assembly and commissioning of all equipment and devices.

8.2.4 Graphics:

All walls of this area will be fully covered by graphics.

8.2.5 Cleaning:

The cleaning of this area will be covered all day long, every day of the fair. There will be a cleaning team dedicated to the cleaning and maintenance of this space, in order to have the area in perfect conditions.

9 INSTITUTIONAL SIGNAGE. ICEX CORPORATE IMAGE

The Spanish pavilions will be marked with the logos detailed in **Annex 4** that identify them with Spain. The areas destined for reception/institutional booths will have a guide panel reflecting the distribution of the different exhibitors, guaranteeing their correct location and the logos FEDER, Foods and Wines from Spain, ICEX and the E España logo. The company awarded the contract will have to comply with the information and publicity measures and the instructions for the application of the European Union emblem, which has its own specifications for agri-food promotion actions with mention of the national origin of the products.

The company will prepare the posters and signage for subsequent production and implementation, Following ICEX instructions.

10 ELECTRICITY AND LIGHTING

The entire installation must comply with the regulations dictated in this respect by the fair authorities, and the successful bidder shall submit all documentation requested for this purpose.

Prior to each assembly, the company awarded the contract will check the suitability of the electrical installation with the fair's technical supervisors.

The successful bidder shall be responsible for the management of the request for electricity contracts and shall submit to ICEX, prior to the final formal request, a summary of the requests to be generated for its approval. **These expenses are not part of the bid price. IceX will pay directly to the Contractor, the amounts that apply and have been previously approved by ICEX.**

The distribution and connections from the outlets to each of the booths, with their complete electrical installation, will be the responsibility of the successful bidder, and must be included in the price of the decoration.

Likewise, when required, there will be specific accessible compartments for the electrical panels and cabinets. These cabinets must be fully integrated into the design and aesthetics of the pavilion and must be freely accessible to the fair organization, avoiding their placement within the storage spaces of the booths.

Lighting equipment must be sufficiently protected for use in the country of assembly and must comply at all times with the technical regulations of the trade fair organization.

11 PLUMBING

The contractor will be in charge of supplying the sinks for the water areas requested for each fair, and according to the situation indicated in the distribution plan to be validated with the successful bidder.

The successful bidder shall be responsible for managing the request for water/drainage connections and shall submit to ICEX, prior to the final formal request, a summary of the requests to be generated for approval. **These expenses are part of the bid price.**

12 CLEANING OF THE PAVILION AND COLLECTION OF DISPOSABLE MATERIALS (during assembly, celebration and dismantling periods).

The awarded company shall deliver the Pavilion completely clean at least 12 hours before the official inauguration.

The awarded company will be responsible for the daily cleaning of the Pavilion during the days of the fair and for the supply of garbage bags and any necessary bins.

In addition to the standard cleaning service indicated above during the days of the fair, the successful bidder will establish a permanent cleaning service to attend both the booths that

cook or do tastings, as well as the washing areas that need an instant and continuous waste and garbage removal service.

The cleaning of the booths will include the storage areas, exhibition furniture (interior and exterior), showcases, shelves, waste garbage cans, chairs, tables, floors and walls.

The cleaning service of the pavilion will be included in the company's offer.

In the event that the regulations of the fairs require the hiring of garbage containers for the removal of disposable materials, the costs of such rental, garbage removal and cleaning of aisles shall be borne by the assembler with regard to waste attributable not only to the exhibitors' material but also to that coming from the construction components of the booths of the Spanish pavilion.

The contractor shall be responsible for organizing and requesting containers for the collection of waste from all the material (constructive and exhibitors of the Spanish pavilion) and **shall be responsible for any payment required by the fair organization for these services.**

The awarded company must comply with the dismantling stands schedule as by the term and provisions contemplated in the Fair Ground Regulations.

13 FEES FOR ADVANCE SET-UP OR RENTAL OF SPACE FOR OUT-OF-HOURS WORK INSIDE THE FAIRGROUNDS

The awardee undertakes to pay any fee corresponding to the rental of space for out-of-hours work within the Fair Precinct, as well as any other fee that may be required by the Fair Organization, both at the beginning and at the end of the Show and which are not contemplated in these specifications.

In this regard, the successful bidder must respect the assembly schedule established by the Fair. Any additional assembly days that must be contracted for the perfect execution of the construction work shall be at the expense of the decorating company.

14 FIRE REGULATIONS

When required by the Fair Organization, the awarded company shall supply, within the bid price, the necessary fire extinguishers to ensure the neutralization of any possible fire incident, with a minimum of one 5 kg. extinguisher for each 100 m² of gross exhibition area.

These will bear the certificate of filling and expiration date. In the event that trade fair regulations require a greater number of extinguishers per m², it shall be the responsibility of the successful bidder to supply them at no extra charge.

All materials used in the construction of the booths must be fireproof and have the certificates of approval required by the organization of the event.

15 SANITARY REGULATIONS

The awarded company shall have a first aid kit in the Pavilion.

The awarded company will supply hydroalcoholic gel to all exhibitors and will mount methacrylate screens on the counters if required by the Fair Organization. The successful bidder undertakes to respect and assume all the required sanitary regulations.

16 OTHERS

The use of the Pavilion shall be on a rental basis.

The facilities will remain at the disposal of ICEX and exhibitors for the duration of the Fair.

The transport and storage of the materials or decorative elements of the Pavilion shall be at the expense of the company awarded the service, which may use any means of transport.

The contractor shall be responsible for the management and contracting with the fair of all the permits necessary for the execution of the Spain Pavilion and for compliance with the fair regulations both in technical aspects and in safety and fire protection. Specifically, the company awarded the contract must ensure that the materials and solutions proposed comply with trade fair regulations.

The awarded company will submit, if requested, the complete project for the Spain Pavilion to the fair organization for approval and authorization within the deadline established by the fair. For this purpose, the Department of Trade Fair Architecture of ICEX will provide, sufficiently in advance, the final plan of the Spain Pavilion, the list of companies participating in the fair and the regulations of the Trade Fair Organization.

The awarded company shall be obliged to comply with any instructions, corrections and modifications that ICEX may send it, both during the design phase and during the assembly of the Spain Pavilion. Likewise, the awarded company shall accept to work jointly and in coordination with the ICEX team.

ICEX reserves the right to inspect and control the quality of the finishes and the manufacturing process of all the materials to be used in the assembly of the Spain Pavilion as many times as it deems necessary. The awarded company shall comply with all guidelines established by ICEX as a result of these inspections.

All materials used in the construction of the booths must have the homologation and fireproofing certificates required by the organizers of the event.

The awarded company will provide the necessary maintenance personnel, including an interlocutor with executive capacity to approve the necessary interventions. These personnel must be physically present at the fair for the duration of the event and be able to communicate in Spanish.

The constructor must expressly undertake to supply the number of units and construction elements of the Spain Pavilion requested by ICEX to meet the needs of exhibitors.

The company will bring to the fair a complete cleaning kit for each institutional retail stand, which will include at least a 6-pack of paper rolls, 2 containers of cleaning fluid, 5 cutters.

Environmental and sustainability considerations: In order to improve management aimed at sustainability, the environmental impact on the surroundings becomes a relevant variable in ICEX activities as differentiating factors that will be mandatory in this project.

To this end, proposals will be sensitive to environmental protection in order to contribute to the prevention of pollution. Environmental management will be considered a strategic element as a competitive advantage over competitors in order for ICEX to become a reference for the sector.

Technical dossier must include:

- a) Location plan.
- b) Architectural plan with dimensions.
- c) Dimensioned general elevations.
- d) Standard booth: elements including the booths (plan, elevations and 3D).
- e) Infographics of the project.
- f) Details of the shelves, show cases and furniture.
- g) Dimensions of each exhibitor graphic wall.
- h) Catalog of the basic furniture set included in the booths, dimensioned and accompanied by photos.

Catalogue of services and additional elements: must include photographs, dimensions, description and price of the following elements:

- a) White chair
- b) White round table 30" Ø
- c) White stool 30" H
- d) White round bar table 24" Ø; 42"H
- e) Showcase counter ((Installation included)
- f) 42" TV (Installation included)
- g) 32" TV (Installation included)
- h) Mini fridge
- i) Refrigerator with freezer
- j) Induction cook top
- k) Storage shelves
- l) Capsule coffee maker
- m) Waste Basket
- n) Extra graphic (CAD/sqft)
- o) Electrical connection 1kW, 10 amp, 24 hrs.
- p) Electrical connection 1kW, 10 amp
- q) Electrical connection 1,5kW, 15 amp, 24 hrs.
- r) Electrical connection 1,5kW, 15 amp
- s) Electrical connection 2kW, 20 amp, 24 hrs.
- t) Electrical connection 2kW, 20 amp

Graphic portfolio: Plan and elevation of each individual stand, outlining all the graphic elements of each of the exhibitors, indicating their position in the general plan.

The awarded company must also provide the following information:

- a) Contact of the person responsible for the awardee company (e-mail and contact telephone number) so that exhibitors participating in the Spanish Pavilion can send the final graphic artwork and make the pertinent queries and requests. The awarded company must manage the receipt of exhibitor's graphics and send them a proof at least 15 days before to approve its printing.
- b) Calendar of dates and work procedures.
- c) 15 days before the fair, the company awarded the contract will send all the updated dossiers, with the changes made, as well as a list of the extra furniture requested by exhibitors to the Department of Architecture of ICEX.
- d) The awardee must build a section of the project in its facilities one month after signing the contract. The costs of assembly and disassembly of this installation shall be borne by the bidder.

ANNEXES

ANNEX 1 – LEGAL DOCUMENTATION TO BE SUBMITTED

Documentation to be submitted by the successful bidder:

- Certificate of Public Liability insurance or a third part risk coverage as per Clause Fourteenth of these Bidding Specifications and in accordance with the requirements settle in the Trade Fair Regulations.

ANNEX 2 – TECHNICAL DOCUMENTATION TO BE SUBMITTED

Documentation to be submitted by the successful bidder:

- The successful bidder shall submit, 15 days before formalizing the contract, a complete project plan for setting up the trade fair. For this purpose, ICEX shall provide in good time the final layout of the Spanish Pavilion, the list of companies taking part in the trade fair and the regulations of the Trade Fair Organization.

ANNEX 3 - SIAL CANADA 2024_Spain'S Design Guidelines

Layout plans are only indicative. A final layout will be sent, if necessary, to the successful bidder in good time before the dates of the Show. The modifications will be built by the contractor at no extra cost.

ANNEX 4 - LOGOS AND CLAIMS

Logos and vector text for flag identification

ANNEX 5 - TYPOGRAPHY

Font file of the fonts described in the tender.

ANNEX 6 - ECONOMICAL OFFER AND AUTOMATIC CRITERIA

Duly fulfilled.